

# Eaton® Power Xpert® 9395

Integrated Battery Cabinet (Model 1085 and 1085HR)  
Installation and Operation Manual



*Powering Business Worldwide*



# **Eaton® Power Xpert® 9395**

Integrated Battery Cabinet (Model 1085 and 1085HR)  
Installation and Operation Manual



*Powering Business Worldwide*

---

**IMPORTANT SAFETY INSTRUCTIONS SAVE THESE INSTRUCTIONS**

---

This manual contains important instructions that you should follow during installation and maintenance of the UPS and batteries. Please read all instructions before operating the equipment and save this manual for future reference.

---

---

**CONSIGNES DE SÉCURITÉ IMPORTANTES CONSERVER CES INSTRUCTIONS**

---

Eaton, Powerware, LanSafe, Powerware Hot Sync, and X-Slot are registered trademarks and ConnectUPS is a trademark of Eaton Corporation or its subsidiaries and affiliates. AS/400 is a registered trademark of International Business Machines Corporation. Modbus is a registered trademark of Schneider Automation. All other trademarks are property of their respective companies.

©Copyright 2020 Eaton, Raleigh, NC, USA. All rights reserved. No part of this document may be reproduced in any way without the express written approval of Eaton.

## TABLE OF CONTENTS

<b>1</b>	<b>INTRODUCTION</b> .....	<b>1-1</b>
1.1	Configuration and Installation Features .....	1-1
1.2	Customer Interface .....	1-1
1.3	UPS Systems Using the Power Xpert 9395 Battery Cabinet .....	1-2
1.4	Using This Manual .....	1-2
1.5	Conventions Used in This Manual .....	1-3
1.6	Symbols, Controls, and Indicators .....	1-3
1.7	For More Information .....	1-4
1.8	Getting Help .....	1-4
1.9	Warranty .....	1-4
<b>2</b>	<b>SAFETY WARNINGS</b> .....	<b>2-1</b>
<b>3</b>	<b>INSTALLATION PLAN AND UNPACKING</b> .....	<b>3-1</b>
3.1	Creating an Installation Plan .....	3-1
3.2	Preparing the Site .....	3-1
3.2.1	Environmental Considerations .....	3-1
3.2.2	Power Wiring Preparation .....	3-5
3.2.3	Interface Wiring Preparation .....	3-8
3.3	Inspecting and Unpacking the Battery Cabinet .....	3-9
<b>4</b>	<b>INSTALLATION</b> .....	<b>4-1</b>
4.1	Preliminary Installation Information .....	4-1
4.2	Unloading the Battery Cabinet from the Pallet .....	4-1
4.3	Model 1085 or 1085HR Battery Cabinet Installation .....	4-3
4.3.1	Mechanical Installation .....	4-3
4.3.2	External Power Wiring Installation .....	4-7
4.3.3	External Interface Wiring Installation .....	4-11
4.3.4	Internal Battery String Connection .....	4-16
4.4	Initial Startup .....	4-17
4.5	Completing the Installation Checklist .....	4-17
	<b>INSTALLATION CHECKLIST</b> .....	<b>4-18</b>
<b>5</b>	<b>ONLINE DRAWINGS AND SCHEMATICS</b> .....	<b>5-1</b>
5.1	Online Drawings .....	5-1
5.2	Schematics .....	5-4
<b>6</b>	<b>MAINTENANCE</b> .....	<b>6-1</b>
6.1	Important Safety Instructions .....	6-1
6.2	Performing Preventive Maintenance .....	6-1
6.2.1	DAILY Maintenance .....	6-1
6.2.2	BATTERY Maintenance .....	6-2
6.3	Installing Batteries .....	6-2
6.4	Recycling the Used Battery or UPS .....	6-2

## TABLE OF CONTENTS

This page intentionally left blank.

## LIST OF FIGURES

Figure 1-1.	Typical Power Xpert 9395 Model 1085 or 1085HR Battery Cabinet . . . . .	1-2
Figure 3-1.	Model 1085 or 1085HR Battery Cabinet Dimensions (Front View) . . . . .	3-3
Figure 3-2.	Model 1085 or 1085HR Battery Cabinet Dimensions (Right Side View) . . . . .	3-3
Figure 3-3.	Model 1085 or 1085HR Battery Cabinet Dimensions (Top View) . . . . .	3-4
Figure 3-4.	Model 1085 or 1085HR Battery Cabinet Dimensions (Bottom View) . . . . .	3-4
Figure 3-5.	Power Xpert 9395 Model 1085 or 1085HR Battery Cabinet as Shipped on Pallet . . . . .	3-10
Figure 4-1.	Removing Shipping Supports . . . . .	4-2
Figure 4-2.	UPS with Model 1085 or 1085HR Battery Cabinet . . . . .	4-4
Figure 4-3.	Battery Cabinet to Battery Cabinet Joining Brackets . . . . .	4-5
Figure 4-4.	Battery Cabinet Bottom Joining Brackets and Ground Wire . . . . .	4-6
Figure 4-5.	Battery Cabinet Hanger Bracket Location . . . . .	4-7
Figure 4-6.	Battery Cabinet Conduit and Wire Entry Locations . . . . .	4-8
Figure 4-7.	1085 Battery Power and Interface Terminal Locations . . . . .	4-9
Figure 4-8.	1085HR Battery Power and Interface Terminal Locations . . . . .	4-10
Figure 4-9.	Battery Breaker Interface Wiring . . . . .	4-12
Figure 4-10.	9395C Battery Breaker Interface Wiring . . . . .	4-13
Figure 4-11.	Terminal Block TB1 Connector Assignments – First Cabinet . . . . .	4-14
Figure 4-12.	Terminal Block TB1 Connector Assignments – Middle Cabinets . . . . .	4-15
Figure 4-13.	Terminal Block TB1 Connector Assignments – Last Cabinet . . . . .	4-15
Figure 4-14.	1085 Battery String Connection . . . . .	4-16
Figure 4-15.	1085HR Battery String Connection . . . . .	4-17
Figure 5-1.	Battery Cabinet Oneline – Common Battery (275 and 500 kVA RT and 275 kVA Plus 1 UPS) . . . . .	5-1
Figure 5-2.	Battery Cabinet Oneline with Disconnect – Common Battery (275 and 500 kVA RT and 275 kVA Plus 1 UPS) . . . . .	5-1
Figure 5-3.	Battery Cabinet Oneline – Separate Battery (275 kVA Plus 1 and 500 kVA RT UPS) . . . . .	5-2
Figure 5-4.	Battery Cabinet Oneline with Disconnect – Separate Battery (275 kVA Plus 1 and 500 kVA RT UPS) . . . . .	5-3
Figure 5-5.	1085 or 1085HR Battery Cabinet with Three-Pole Breaker Power Wiring Schematic . . . . .	5-4
Figure 5-6.	Battery Cabinet Breaker CB1 Control Wiring Schematic – First Cabinet . . . . .	5-5
Figure 5-7.	Battery Cabinet Breaker CB1 Control Wiring Schematic – Middle Cabinets . . . . .	5-5
Figure 5-8.	Battery Cabinet Breaker CB1 Control Wiring Schematic – Last Cabinet . . . . .	5-6

This page intentionally left blank.



## Chapter 1 Introduction

The 9395 battery cabinet is designed to use with the 9395, 9395P, and 9395C. The primary difference is the 9395C uses an Under Voltage Relay instead of a Shunt Trip device to control the battery breaker.

During brownouts, blackouts, and other power interruptions, battery cabinets provide emergency DC power to the UPS to safeguard operation of the critical load. The Integrated Battery Cabinet (IBC) systems are housed in single free-standing cabinets. Model 1085 or 1085HR with a single battery voltage range is available to meet application runtime needs. Up to six cabinets may be installed to further extend battery runtime. The cabinets match the UPS cabinet in style and color. Figure 1-1 shows the Power Xpert 9395 Model 1085 or 1085HR Battery Cabinet.

---

### CAUTION


---

The 1085 and 1085HR battery cabinets CANNOT be intermixed. Serious damage to equipment may result.

---

Mechanical lugs located at the front of the cabinet reduce installation time, and removable battery trays with quick disconnects between trays reduce battery maintenance time. A DC-rated circuit breaker within each cabinet provides protection and servicing isolation.

---

**NOTE**  Startup and operational checks must be performed by an authorized Eaton Customer Service Engineer, or the warranty terms specified on page W-1 become void. This service is offered as part of the sales contract for the UPS system. Contact service in advance (usually a two-week notice is required) to reserve a preferred startup date.

---

### 1.1 Configuration and Installation Features

The 9395 Model 1085 battery cabinet is designed to be installed in a standalone configuration using two to six battery cabinets. Power wiring is installed externally between each battery cabinet and the UPS or battery disconnect using conduit. Battery cabinets may be installed adjacent to the UPS or in a separate location.

If the battery cabinet is installed adjacent to the UPS, the recommended installation location for the battery cabinet is on the right side of the UPS cabinet. This location will allow for future expansion using an external module.

Cabinets can be permanently bolted to the floor or left standing on leveling feet.


Power and control wiring can be routed through the top or bottom of the cabinet depending on installation configuration. Connections are made to easily accessible terminals.

### 1.2 Customer Interface

Battery breaker shunt trip terminals are provided to connected the battery cabinet to the UPS. The shunt trip is used to open the battery breaker in the event of an emergency or rapid shutdown of the UPS system.

---

**NOTE** The 9395C uses a UVR instead of the shunt trip in the battery breaker.

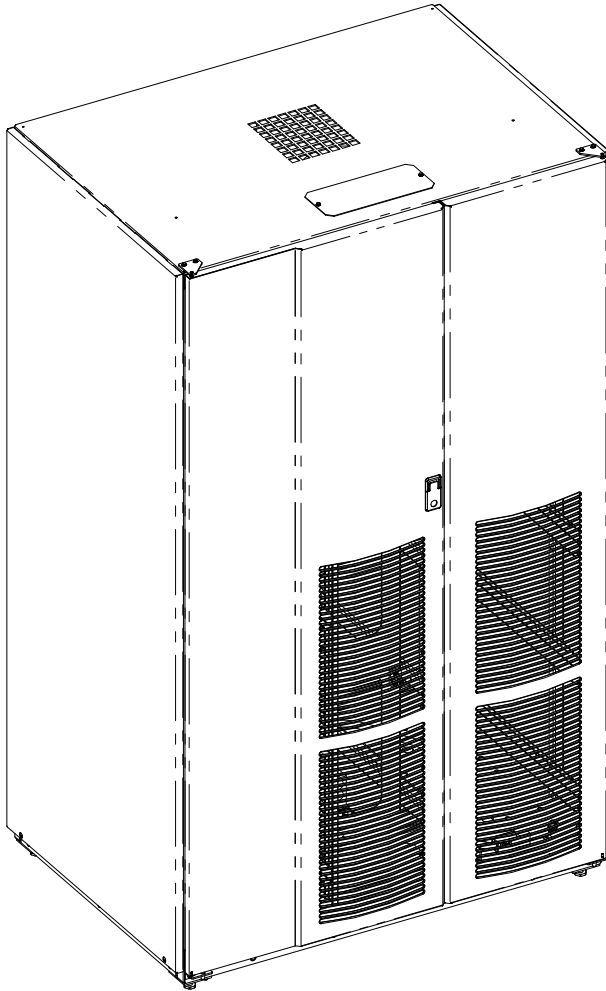
**NOTE**  The 9395 system can trip a maximum of six battery cabinets total. This applies to both the 1085 standard and High Rate series batteries. If more than six battery cabinets in total are needed in a separate UPM battery configuration, DO NOT hook up the shunt trips. Instead, use external hardware to perform the shunt trip function.

---

Auxiliary contact terminals are provided to signal when the battery breaker is closed or open.

### 1.3 UPS Systems Using the Power Xpert 9395 Battery Cabinet

Most of the 9395, and 9395P models can use the 1085 battery cabinets. All ratings of the Power Xpert UPS can use the 1085HR battery cabinets including the 9395C.



**Figure 1-1. Typical Power Xpert 9395 Model 1085 or 1085HR Battery Cabinet**

### 1.4 Using This Manual

This manual describes how to install the Power Xpert 9395 battery cabinet. Read and understand the procedures described in this manual to ensure trouble-free installation.


Read through each procedure before beginning the procedure. Perform only those procedures that apply to the battery system being installed.

Refer to the appropriate Power Xpert 9395, 9395P, or 9395C UPS Installation and Operation manual for circuit breaker, control and power wiring, and installation specifications.

## 1.5 Conventions Used in This Manual

This manual uses these type conventions:

- **Bold type** highlights important concepts in discussions, key terms in procedures, and menu options, or represents a command or option that you type or enter at a prompt.
- *Italic type* highlights notes and new terms where they are defined.
- `Screen type` represents information that appears on the screen or LCD.

Icon	Description
	Information notes call attention to important features or instructions.
[Keys]	Brackets are used when referring to a specific key, such as [Enter] or [Ctrl].

In this manual, the term *UPS* refers only to the UPS cabinet and its internal elements. The term *UPS system* refers to the entire power protection system – the UPS cabinet, the battery cabinet, and options or accessories installed.

The term *standalone* refers to battery cabinets that may be installed adjacent to the UPS or in a separate location, are wired with external customer-supplied conduit and wiring, and may use the battery cabinet breaker as the battery isolation device or a single overcurrent protection and disconnect device located near the batteries.

## 1.6 Symbols, Controls, and Indicators

The following are examples of symbols used on the UPS or accessories to alert you to important information:



**RISK OF ELECTRIC SHOCK** - Observe the warning associated with the risk of electric shock symbol.



**CAUTION: REFER TO OPERATOR'S MANUAL** - Refer to your operator's manual for additional information, such as important operating and maintenance instructions.



This symbol indicates that you should not discard the UPS or the UPS batteries in the trash. This product contains sealed, lead-acid batteries and must be disposed of properly. For more information, contact your local recycling/reuse or hazardous waste center.



This symbol indicates that you should not discard waste electrical or electronic equipment (WEEE) in the trash. For proper disposal, contact your local recycling/reuse or hazardous waste center.

## 1.7 For More Information

Refer to the appropriate rated Power Xpert UPS manual listed in section 1.3 for the following additional information:

- UPS cabinet, optional components, and accessory installation instructions, including site preparation, planning for installation, and wiring and safety information. Detailed illustrations of cabinets and optional accessories with dimensional and connection point drawings are provided.
- UPS operation, including UPS cabinet controls, functions of the UPS, standard features and optional accessories, procedures for starting and stopping the UPS, and information about maintenance and responding to system events. Communication capabilities of the UPS system.
- Communication capabilities of the UPS system.

Visit [www.eaton.com/powerquality](http://www.eaton.com/powerquality) or contact an Eaton service representative for information on how to obtain copies of these manuals.

## 1.8 Getting Help

If help is needed with any of the following:

- Scheduling initial startup
- Regional locations and telephone numbers
- A question about any of the information in this manual
- A question this manual does not answer

Please call the Customer Reliability Center at:

United States:	<b>1-800-843-9433</b> or <b>1-919-870-3028</b>
Canada:	<b>1-800-461-9166 ext 260</b>
All other countries:	<b>Call your local service representative</b>

Please use the following e-mail address for manual comments, suggestions, or to report an error in this manual:

**[E-ESSDocumentation@eaton.com](mailto:E-ESSDocumentation@eaton.com)**

## 1.9 Warranty

To view the UPS warranty please click on the link or copy the address to download from the Eaton website:

[UPS Product Warranty](#)

<https://www.eaton.com/content/dam/eaton/products/backup-power-ups-surge-it-power-distribution/backup-power-ups/portfolio/eaton-three-phase-ups-warranty.pdf>

## Chapter 2 Safety Warnings

---

### IMPORTANT SAFETY INSTRUCTIONS SAVE THESE INSTRUCTIONS

---

This manual contains important instructions that should be followed during installation and maintenance of the batteries. Read all instructions before operating the equipment and save this manual for future reference.

The battery cabinet is designed for industrial or computer room applications and should be handled with appropriate care.

---

### DANGER

---

This battery cabinet contains **LETHAL VOLTAGES**. All repairs and service should be performed by **AUTHORIZED SERVICE PERSONNEL ONLY**. There are **NO USER SERVICEABLE PARTS** inside the UPS.

---

### DANGER!

---

Cet onduleur peut générer des **TENSIONS MORTELLES**. L'installation et l'entretien ne doivent être effectués que par le **PERSONNEL AUTORISÉ**. Ne contient **AUCUNE PIÈCE REMPLAÇABLE**.

---

### WARNING

---

- This battery cabinet contains its own energy source. The internal wiring and output terminals may carry live voltage even when the UPS is not connected to an AC source.
- To reduce the risk of fire or electric shock, install this UPS in a temperature and humidity controlled, indoor environment, free of conductive contaminants. Ambient temperature must not exceed 40°C (104°F). Do not operate near water or excessive humidity (95% maximum). The system is not intended for outdoor use.
- Ensure all power is disconnected before performing installation or service.
- Batteries can present a risk of electrical shock or burn from high short-circuit current. The following precautions should be observed: 1) Remove watches, rings, or other metal objects; 2) Use tools with insulated handles; 3) Do not lay tools or metal parts on top of batteries; 4) Wear rubber gloves and boots.
- **ELECTRIC ENERGY HAZARD**. Do not attempt to alter any battery wiring or connectors. Attempting to alter wiring can cause injury.
- Do not open or mutilate batteries. Released electrolyte is harmful to the skin and eyes. It may be toxic.

---

### CAUTION

---

- Installation or servicing should be performed by qualified service personnel knowledgeable of UPS and battery systems, and required precautions. Keep unauthorized personnel away from equipment. Consider all warnings, cautions, and notes before installing or servicing equipment. **DO NOT DISCONNECT** the batteries while the UPS is in Battery mode.
- Replace batteries with the same number and type of batteries as originally installed in the battery cabinet.
- Disconnect the charging source prior to connecting or disconnecting terminals.
- Determine if the battery is inadvertently grounded. If it is, remove the source of the ground. Contacting any part of a grounded battery can cause a risk of electric shock. An electric shock is less likely if you disconnect the grounding connection before you work on the batteries.

- Proper disposal of batteries is required. Refer to local codes for disposal requirements.
- Never dispose of batteries in a fire. Batteries may explode when exposed to flame.
- Keep the battery cabinet doors closed to ensure proper cooling airflow and to protect personnel from dangerous voltages inside the unit.
- Do not install or operate the battery cabinet close to gas or electric heat sources.
- The operating environment should be maintained within the parameters stated in this manual.
- Operating temperatures above the recommended range will result in decreased battery life and performance, and will reduce or void the battery warranty. Refer to Terms and Conditions of Sale with Battery Replacement Coverage and the Battery Replacement Price Book for more information. These documents can be found at [www.eaton.com/powerquality](http://www.eaton.com/powerquality) or contact your service representative for information on how to obtain copies.
- Keep surroundings uncluttered, clean, and free from excess moisture.
- Observe all DANGER, CAUTION, and WARNING notices affixed to the inside and outside of the equipment.



### **AVERTISSEMENT!**

---

- Les batteries peuvent présenter un risque de décharge électrique ou de brûlure par des courts-circuits de haute intensité. Prendre les précautions nécessaires.
- Pour le remplacement, utiliser le même nombre et modèle des batteries.



### **ATTENTION!**

---

- Une mise au rebut réglementaire des batteries est obligatoire. Consulter les règlements en vigueur dans votre localité.
- Ne jamais jeter les batteries au feu. L'exposition aux flammes risque de les faire exploser.

## Chapter 3 Installation Plan and Unpacking

Use the following basic sequence of steps to install the UPS:

1. Create an installation plan for the battery cabinet (Chapter 3).
2. Prepare your site for the battery cabinet (Chapter 3).
3. Inspect and unpack the battery cabinet (Chapter 3).
4. Unload and install the battery cabinet, and wire the system (Chapter 4).
5. Complete the Installation Checklist (Chapter 4).
6. Have authorized service personnel perform preliminary operational checks and start up the system.



**NOTE** Startup and operational checks must be performed by an authorized Eaton Customer Service Engineer, or the warranty terms specified on page W-1 become void. This service is offered as part of the sales contract for the UPS. Contact an Eaton service representative in advance (a minimum two-week notice is required) to reserve a preferred startup date.

---

### 3.1 Creating an Installation Plan

Before installing the battery cabinet, read and understand how this manual applies to the system being installed. Use the procedures and illustrations in paragraph 3.2 and Chapter 4 to create a logical plan for installing the system.

### 3.2 Preparing the Site

For the UPS system to operate at peak efficiency, the installation site should meet the environmental parameters outlined in this manual. If the UPS is to be operated at an altitude higher than 1000m (3300 ft), contact an Eaton service representative for important information about high altitude operation. The operating environment must meet the weight, clearance, and environmental requirements specified.

#### 3.2.1 Environmental Considerations

The battery system installation must meet the listed guidelines. Failure to follow guidelines may void your warranty.

- The system must be installed on a level floor suitable for computer or electronic equipment.
- If perforated floor tiles are required for ventilation, place them in front of the battery cabinet.
- The system must be installed in a temperature and humidity controlled indoor area free of conductive contaminants.
- The battery cabinet is to be installed in a *standalone* configuration.
- The recommended installation location for battery cabinets located adjacent to the UPS is on the right side of the UPS cabinet. This location will allow for future expansion using an external module.

The battery equipment operating environment must meet the weight requirements shown in Table 3-1 and the size requirements shown in Figure 3-1 through Figure 3-4. The weight shown in Table 3-1 is the maximum weight of a fully configured cabinet. The weight of your cabinet may be less due to its configuration.

**Table 3-1. Maximum Battery Cabinet Weight**

Model	Weight kg (lb)		
	Shipping	Installed	Point Loading
Power Xpert 9395 1085 or 1085HR with 40 batteries (480 Vdc)	2368 (5221)	2327 (5130)	8 at 291 (642)

The battery cabinet uses convection air cooling to regulate internal component temperature. Air inlets are in the front of the cabinet and outlets are in the top. Allow clearance in front of and above each cabinet for proper air circulation. The clearances required around the battery cabinet are shown in Table 3-2. Dimensions are in millimeters (inches).

**Table 3-2. UPS Cabinet Clearances**

<b>From Top of Cabinet</b>	Minimum clearance over the UPS cabinet is 457.2 mm (18") minimum for ventilation
<b>From Front of Cabinet</b>	1067 mm (42") working space
<b>From Back of Cabinet</b>	None Required
<b>From Right Side of Cabinet</b>	None Required
<b>From Left Side of Cabinet</b>	None Required

The basic environmental requirements of both Models IBC-S and IBC-L for operation of the battery system are:

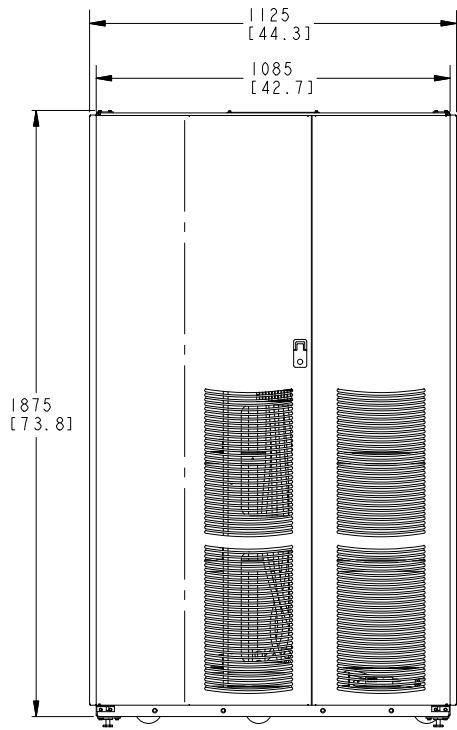
- Operational Temperature Range: 22-28°C (72-82°F)
- Maximum Relative Humidity: 95%, non-condensing



**NOTE**

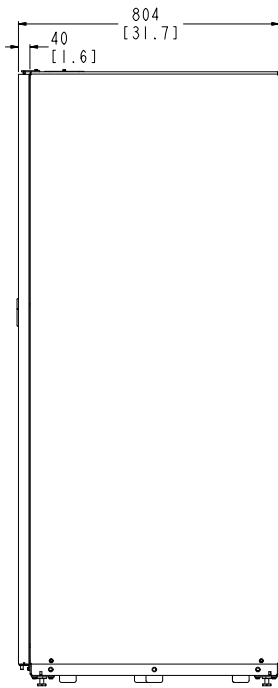
It is recommended for optimal battery life and discharge performance to keep the ambient air temperature the battery is used in at 25°C (77°F). Operating temperatures above the recommended range will result in decreased battery life and performance, and will reduce or void the battery warranty. Refer to Eaton's Terms and Conditions of Sale with Battery Replacement Coverage and the Battery Replacement Price Book for more information. These documents can be found at [www.eaton.com/powerquality](http://www.eaton.com/powerquality) or contact your service representative for information on how to obtain copies.





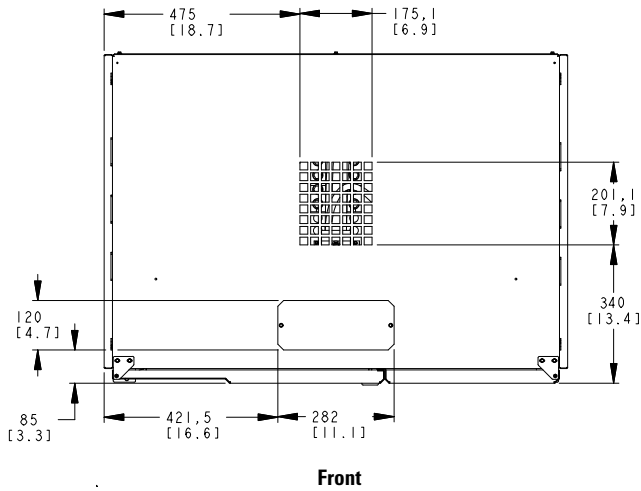
DIMENSIONS ARE IN MILLIMETERS [INCHES]

**Figure 3-1. Model 1085 or 1085HR Battery Cabinet Dimensions (Front View)**



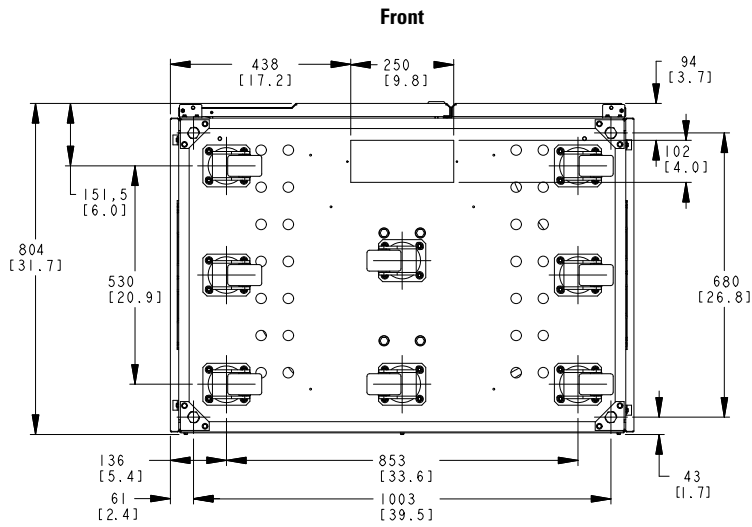
DIMENSIONS ARE IN MILLIMETERS [INCHES]

**Figure 3-2. Model 1085 or 1085HR Battery Cabinet Dimensions (Right Side View)**



DIMENSIONS ARE IN MILLIMETERS [INCHES]

**Figure 3-3. Model 1085 or 1085HR Battery Cabinet Dimensions (Top View)**



DIMENSIONS ARE IN MILLIMETERS [INCHES]

**Figure 3-4. Model 1085 or 1085HR Battery Cabinet Dimensions (Bottom View)**

### 3.2.2 Power Wiring Preparation

Read and understand the following notes while planning and performing the power wiring installation:

---

#### CAUTION

---

The 1085 and 1085HR battery cabinets CANNOT be intermixed. Serious damage to equipment may result.

---

#### **NOTE** **Battery Conductor Sizing:**

- For optimum system performance and battery run time, Eaton strongly recommends using the specified DC conductor size and quantity shown in the UPS Installation and Operation Manual.



#### **Cable Routing, Conduit Applications:**

- Each conduit must have a Positive, Negative, and Ground conductor.
- There must be an equal number of positive and negative conductors in a single conduit. Only one ground conductor is required in each conduit.

#### **Cable Routing, Raceway Applications:**

- Each conduit must have a Positive, Negative, and Ground conductor.
  - Positive and negative battery cables must be run side by side in the raceway in an alternating pattern (+ - + - + -).
  - There must be a ground cable running in the raceway with the battery cables.
- 

- Refer to national and local electrical codes for acceptable external wiring practices.
- Material and labor for external wiring requirements are to be provided by designated personnel.
- For external wiring, use 90°C copper wire. See the appropriate Power Xpert 9395 UPS Installation and Operation manual listed in paragraph 1.7. Wire sizes are based on using the specified breakers.
- Refer to NEC Article 250 and local codes for proper grounding practices.
- The battery cabinet frame is not referenced to the DC circuit.
- Battery voltage is computed at 2 volts per cell as defined by Article 480 of the NEC. Rated battery current is computed at 2 volts per cell.
- The battery wiring used between the battery and the UPS should not allow a voltage drop of more than **2 VDC** at rated battery current.
- The battery cabinet is installed in a standalone configuration. The term standalone refers to battery cabinets that are installed adjacent to the UPS without mechanical linkage or in a separate location, are wired with external customer-supplied conduit and wiring, and may use the battery cabinet breaker as the battery isolation device or a single overcurrent protection and disconnect device located near the batteries.
- Each battery cabinet has its own overcurrent protection device with a built-in shunt trip (or UVR for 9395C) feature that must be used in all configurations.
- Refer to the appropriate Power Xpert 9395 UPS Installation and Operation manual listed in paragraph 1.7 for UPS cabinet conduit and terminal specifications and locations.
- The Environmental Monitoring Probe (EMP), for remote monitoring of battery environmental conditions, must be installed and set up by your service representative, or the battery warranty terms specified on page W-1 become void.
- The battery cabinet is shipped with a debris shield covering the ventilation grill on top of the unit. Do not remove the debris shield until installation is complete. However, remove the shield before using the battery cabinet. Once the debris shield is removed, do not place objects on the ventilation grill.

## Installation Plan and Unpacking

Refer to Tables 3-3 to 3-5 and the appropriate Power Xpert 9395, 9395P, or 9395C UPS Installation and Operation manual for external wiring requirements, including the minimum AWG size of external wiring. The power wiring connections for this equipment are rated at 90°C. If wire is run in an ambient temperature greater than 30°C, higher temperature wire and/or larger size wire may be necessary.

**Table 3-3. External Power Wiring Requirements for Power Xpert 9395 Model 1085/1085HR Battery Cabinet to UPS or to Common Disconnect**

UPS Model Power Xpert 9395 kVA/kW	Minimum Number of Cabinets per UPS	Battery Terminal	Minimum Conductor Size (AWG) 90° C Copper	Number per Pole	Wires/Conduit	Conduit (EMT) Trade Size
275/225	1	(+)(-)	500	1	2+GND	2.5
275/250	2	(+)(-)	500	1	2+GND	2.5
275/275	2	(+)(-)	500	1	2+GND	2.5
300/300	3	(+)(-)	500	1	2+GND	2.5
550/400	3	(+)(-)	500	1	2+GND	2.5
550/450	3	(+)(-)	500	1	2+GND	2.5
550/500	4	(+)(-)	500	1	2+GND	2.5
550/550	4	(+)(-)	500	1	2+GND	2.5
825/600	5	(+)(-)	500	1	2+GND	2.5
825/650	5	(+)(-)	500	1	2+GND	2.5
825/750	6	(+)(-)	500	1	2+GND	2.5
825/825	6	(+)(-)	500	1	2+GND	2.5
1100/900	7	(+)(-)	500	1	2+GND	2.5
1100/1000	7	(+)(-)	500	1	2+GND	2.5
1100/1100	7	(+)(-)	500	1	2+GND	2.5
All	All	Ground	3	1	2+GND	2.5

**NOTE** This table is not to be used for wire sizing from common disconnect to UPS. For that refer to the UPS manual.

**Table 3-4. External Power Wiring Requirements for Power Xpert 9395P Model 1085/1085HR Battery Cabinet to UPS or to Common Disconnect**

UPS Model Power Xpert 9395P kVA/kW	Minimum Number of Cabinets per UPS	Battery Terminal	Minimum Conductor Size (AWG) 90° C Copper	Number per Pole	Wires/Conduit	Conduit (EMT) Trade Size
300/200	1	(+)(-)	500	1	2+GND	2.5
300/225	1	(+)(-)	500	1	2+GND	2.5
300/250	2	(+)(-)	500	1	2+GND	2.5
300/275	2	(+)(-)	500	1	2+GND	2.5
300/300	3	(+)(-)	500	1	2+GND	2.5
600/400	3	(+)(-)	500	1	2+GND	2.5
600/450	3	(+)(-)	500	1	2+GND	2.5
600/500	4	(+)(-)	500	1	2+GND	2.5
600/550	4	(+)(-)	500	1	2+GND	2.5
600/600	5	(+)(-)	500	1	2+GND	2.5
900/675	5	(+)(-)	500	1	2+GND	2.5
900/750	6	(+)(-)	500	1	2+GND	2.5
900/825	6	(+)(-)	500	1	2+GND	2.5

**Table 3-4. External Power Wiring Requirements for Power Xpert 9395P Model 1085/1085HR Battery Cabinet to UPS or to Common Disconnect (Continued)**

UPS Model Power Xpert 9395P kVA/kW	Minimum Number of Cabinets per UPS	Battery Terminal	Minimum Conductor Size (AWG) 90° C Copper	Number per Pole	Wires/Conduit	Conduit (EMT) Trade Size
900/900	7	(+)(-)	500	1	2+GND	2.5
1200/1000	7	(+)(-)	500	1	2+GND	2.5
1200/1100	8	(+)(-)	500	1	2+GND	2.5
1200/1200	8	(+)(-)	500	1	2+GND	2.5
All	All	Ground	3	1	2+GND	2.5

**NOTE** This table is not to be used for wire sizing from common disconnect to UPS. For that refer to the UPS manual.

**Table 3-5. External Power Wiring Requirements for Power Xpert 9395C Model 1085/1085HR Battery Cabinet to UPS or to Common Disconnect**

UPS Model Power Xpert 9395C kVA/kW	Minimum Number of Cabinets per UPS	Battery Terminal	Minimum Conductor Size (AWG) 90° C Copper	Number per Pole	Wires/Conduit	Conduit (EMT) Trade Size
1100/1000	8	(+)(-)	500	1	2+GND	2.5
1100/1100	8	(+)(-)	500	1	2+GND	2.5

**NOTE** This table is not to be used for wire sizing from common disconnect to UPS. For that refer to the UPS manual.

Battery terminals consist of pressure terminations, UL and CSA rated at 90°C, and 1-hole bus bar mountings for standard NEMA 1-hole barrel lugs. See Table 3-6 for power cable termination requirements. See Chapter 4, “Installation” for the location of the power cable terminals inside the battery cabinet.

**Table 3-6. Power Cable Terminations for the Power Xpert 9395 Model 1085 or 1085HR Battery Cabinet**

Terminal Function	Terminal	Function	Type	Terminations	Tightening Torque Nm (lb ft)	Size and Type of Screw or Bolt Size
DC Input and Output	Battery (+)	Positive	Pressure	2 - #2-600 kcmil	42.4 (375)	3/8" Hex
			Bolt	2 - 1 Bolt Mounting	22.6 (200)	M10 Hex
	Battery (-)	Negative	Pressure	2 - #2-600 kcmil	42.4 (375)	3/8" Hex
			Bolt	2 - 1 Bolt Mounting	22.6 (200)	M10 Hex
Ground	Ground	Ground	Pressure	2 - #14-1/0	5.6 (50)	7/16" Slot

NOTE Customer ground, sized in accordance with NEC Table 250.122, can be run in any conduit listed. Refer to the appropriate UPS manual.

A battery disconnect switch is recommended, and may be required by NEC or local codes when batteries are remotely located. The battery disconnect switch should be installed between the battery and the UPS.

External DC input overcurrent protection and disconnect switch for the remote battery location is to be provided by the user. Refer to the appropriate Power Xpert 9395, 9395P, or 9395C UPS Installation and Operation manual for the maximum rating for continuous-duty rated circuit breakers satisfying the criteria for both.

## 3.2.3 Interface Wiring Preparation

Read and understand the following notes while planning and performing the Interface wiring installation:

- Control wiring for Battery Aux contacts should be connected at the customer interface connectors or terminal located inside the battery cabinet. Use Class 1 wiring methods (as defined by the NEC) for interface wiring up to 30V. The wire should be a minimum of 18 AWG rated at 24V, 1A minimum.



---

**NOTE**

The 9395 system can trip a maximum of six battery cabinets total. This applies to both the 1085 standard and High Rate series batteries. If more than six battery cabinets in total are needed in a separate UPM battery configuration, DO NOT hook up the shunt trips. Instead, use external hardware to perform the shunt trip function.

---

- The Shunt Trip requires 48 Vdc to activate. Use Class 2 wiring methods (as defined by the NEC) for interface wiring from 30 to 600V. The wiring should be a minimum of 18 AWG rated at 48V, 1A minimum.
- The 9395C uses a UVR in the breaker that requires 48 Vdc to operate. Use Class 2 wiring methods (as defined by the NEC) for interface wiring from 30 to 600V. The wiring should be a minimum of 18 AWG rated at 48V, 1A minimum.
- All interface wiring between the UPS and battery cabinet is to be provided by the customer.
- When installing external interface wiring (for example, battery breaker shunt trip) to the battery cabinet interface terminals, conduit must be installed between the battery cabinets and the UPS cabinet. Install the interface wiring in separate conduit from the power wiring.
- The Battery Aux and 48 Vdc Shunt Trip (or UVR) signal wiring from the UPS must be connected to the DC source disconnect device.
- Torque screw terminals to 20 lb in.
- Auxiliary Contact Ratings:
  - 240 Vac @ 15A
  - 125 Vdc @ 0.3A
  - 250 Vdc @ 0.15A
- See Chapter 4, “Battery Cabinet Installation.” for the location of the customer interface terminals inside the battery cabinet.
- Refer to the appropriate Power Xpert 9395 UPS Installation and Operation Manual, as referenced in paragraph 1.7 for UPS cabinet conduit and terminal specifications and locations.

### 3.3 Inspecting and Unpacking the Battery Cabinet

The battery cabinet is palletted separately for shipping. The cabinet is shipped bolted to a pallet consisting of four angle metal supports secured to two four-inch by six-inch wood supports, as shown in Figure 3-5 and protected with outer protective packaging material.

---

 **CAUTION**

---

The battery cabinet is extremely heavy (see Table 3-1). If unpacking instructions are not closely followed, the cabinet may tip and cause serious injury.

---

1. Carefully inspect the outer packaging for evidence of damage during transit.


---

 **CAUTION**

---

Do not install a damaged cabinet. Report any damage to the carrier and contact your service representative immediately.

---

 **NOTE** For the following step, verify that the forklift or pallet jack is rated to handle the weight of the cabinet (see Table 3-1 for cabinet weight).

---

2. Use a forklift or pallet jack to move the packaged cabinet to the installation site, or as close as possible, before unpacking. Insert the forklift or pallet jack's forks between the pallet supports on the bottom of the unit.

---


 **CAUTION**

---

Do not tilt the UPS cabinet more than 10° from vertical or the cabinet may tip over.


---

3. Set the pallet on a firm, level surface, allowing a minimum clearance of 3m (10 ft) on each side for removing the cabinet from the pallet.

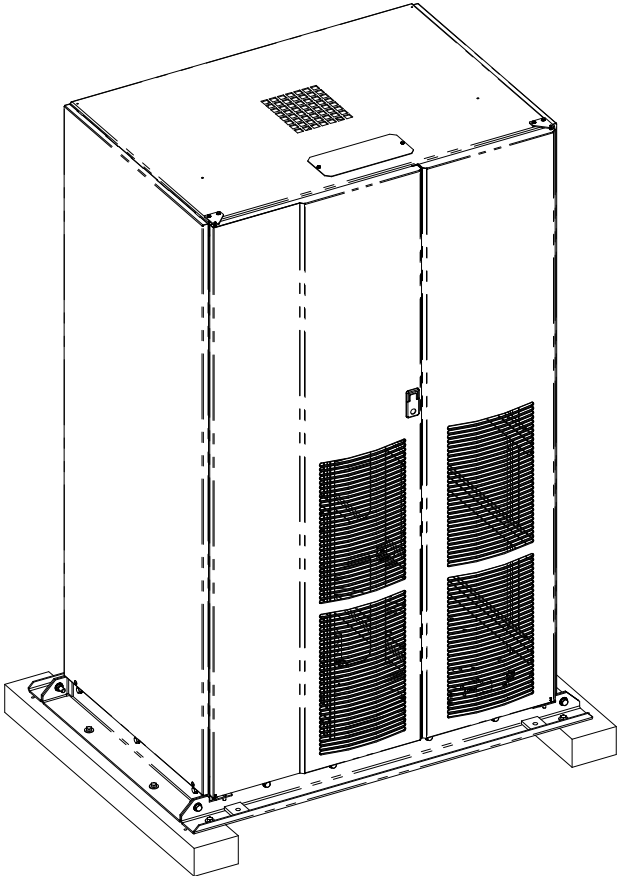
 **NOTE** The battery cabinet is shipped with a debris shield covering the ventilation grill on top of the unit. Do not remove the debris shield until installation is complete.

---

4. Remove the protective covering from the cabinet.
5. Remove the packing material, and discard or recycle in a responsible manner.
6. Inspect the contents for any evidence of physical damage, and compare each item with the Bill of Lading. If damage has occurred or shortages are evident, contact your service representative immediately to determine the extent of the damage and its impact upon further installation.

 **NOTE** While waiting for installation, protect the unpacked cabinet from moisture, dust, and other harmful contaminants. Failure to store and protect the UPS properly may void your warranty.

---



**Figure 3-5. Power Xpert 9395 Model 1085 or 1085HR Battery Cabinet as Shipped on Pallet**



## Chapter 4 Installation

### 4.1 Preliminary Installation Information

---

 **WARNING**

Installation should be performed only by qualified personnel knowledgeable of batteries and their associated precautions. Keep unauthorized personnel away from battery cabinets.

---

---

 **CAUTION**

The 1085 and 1085HR battery cabinets CANNOT be intermixed. Serious damage to equipment may result.

---

Observe these precautions when working on or around battery cabinets:

- Remove watches, rings, or other metal objects.
- Use tools with insulated handles.
- Wear rubber gloves and boots.
- Do not lay tools or metal parts on top of batteries or battery cabinets.

Refer to the following while installing the battery system:

- Chapter 3 for cabinet dimensions, equipment weight, wiring and terminal data, and installation notes.
- Refer to the applicable Power Xpert 9395 UPS Installation and Operation Manual listed in paragraph 1.7 for UPS cabinet conduit and terminal specifications and locations.
- The conduit landing plates are to be removed to add conduit landing holes as required. Plate material is 16 gauge steel (1.5 mm/0.06" thick).
- The recommended installation location for battery cabinets located adjacent to the UPS is on the right side of the UPS cabinet. This location will allow for future expansion using an external module.

### 4.2 Unloading the Battery Cabinet from the Pallet

The battery cabinet is bolted to a pallet consisting of four angle metal supports secured to two four-inch by six-inch wood supports.

---

 **WARNING**

The battery cabinet is heavy. See Table 3-1 for weight of cabinets. If unloading instructions are not closely followed, the cabinet may cause serious injury.

---

---

 **CAUTION**

- Do not tilt cabinets more than 10° from vertical.
- Lift the cabinets only with a forklift or damage may occur.

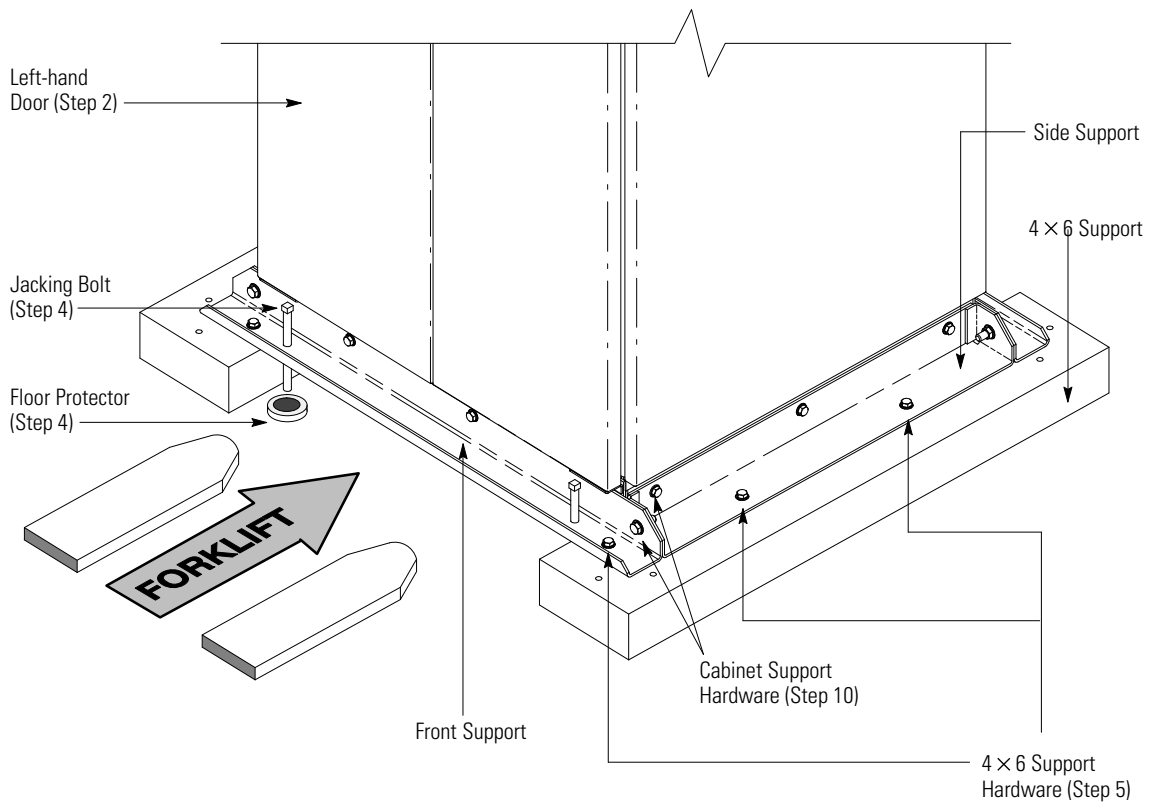


**NOTE** For the following steps, verify that the forklift or pallet jack is rated to handle the weight of the cabinet (see Table 3-1 for cabinet weight).

---

To remove the pallet and mechanically install the UPS:

1. If not already accomplished, use a forklift to move the cabinet to the installation area, or as close as possible, before unloading from the pallet. Insert the forklift from the front of the cabinet (see Figure 4-1).
2. Unfasten the front door latch and swing the doors open.
3. Remove the doors. Remove the retaining screw located inside each door at the bottom hinge pivot point, then lift the door off. Save the retaining screws for re-installation of the doors.
4. Locate the field kit (packed inside of the cabinet). Locate the four 1/2" jacking bolts and install them in the threaded holes in the front and rear supports. Place a floor protector underneath each jacking bolt, and screw the bolts down against them. The floor protectors protect the floor from being marred by the jacking bolts. Retain the remaining parts of the field kit for later use.



**Figure 4-1. Removing Shipping Supports**

5. Loosen, but do not remove, the hardware holding the 4 x 6 supports to the front and rear supports.

---

**⚠ WARNING**

---

SERIOUS INJURY MAY OCCUR. Battery cabinets are extremely heavy. If unloading instructions are not closely followed, cabinet may tip.

---

6. Turn each jacking bolt consecutively, two full turns, until the 4 x 6 supports clear the floor by approximately 3 mm (1/8").

---

 **WARNING**


---

RISK OF INSTABILITY. Turning the jacking bolts unevenly may cause the cabinet to become unbalanced. To prevent tipping the cabinet, raise and lower the jacking bolts evenly.

---

 **CAUTION**


---

CABINET MAY TIP. The battery cabinet should only be raised approximately 3 mm (1/8") above the floor (just enough to allow removal of the 4 x 6 supports).

---

7. Remove the hardware loosened in Step 5. Pull the 4 x 6 supports out from under the battery cabinet. Discard or recycle them in a responsible manner.
- 

 **CAUTION**


---

CABINET MAY FALL. Do not loosen the hardware attaching the side or front supports to the cabinet base, or the front and side supports to each other, at this time. The cabinet must be lowered by the jacking bolts before the supports can be removed.

---

8. Carefully and evenly **lower the cabinet by turning each jacking bolt consecutively two full turns (maximum)** until the casters contact the floor, and the cabinet is no longer supported by the jacking bolts.
9. Remove the jacking bolts and discard or recycle them in a responsible manner.
10. Remove the hardware holding the front, rear, and side supports to the cabinet base. Discard or recycle the hardware and support brackets in a responsible manner.
11. Roll the battery cabinet to its final location.
12. Repeat Steps 3 through 11 for each cabinet you are preparing to install.

### 4.3 Model 1085 or 1085HR Battery Cabinet Installation

The 9395 Model 1085 or 1085HR battery cabinet is designed to be installed in a standalone configuration. Customer-supplied conduit and wiring is installed externally between each battery cabinet and the UPS or UPS disconnect. Battery cabinets may be installed adjacent to the UPS or in a separate location.

---

 **CAUTION**


---

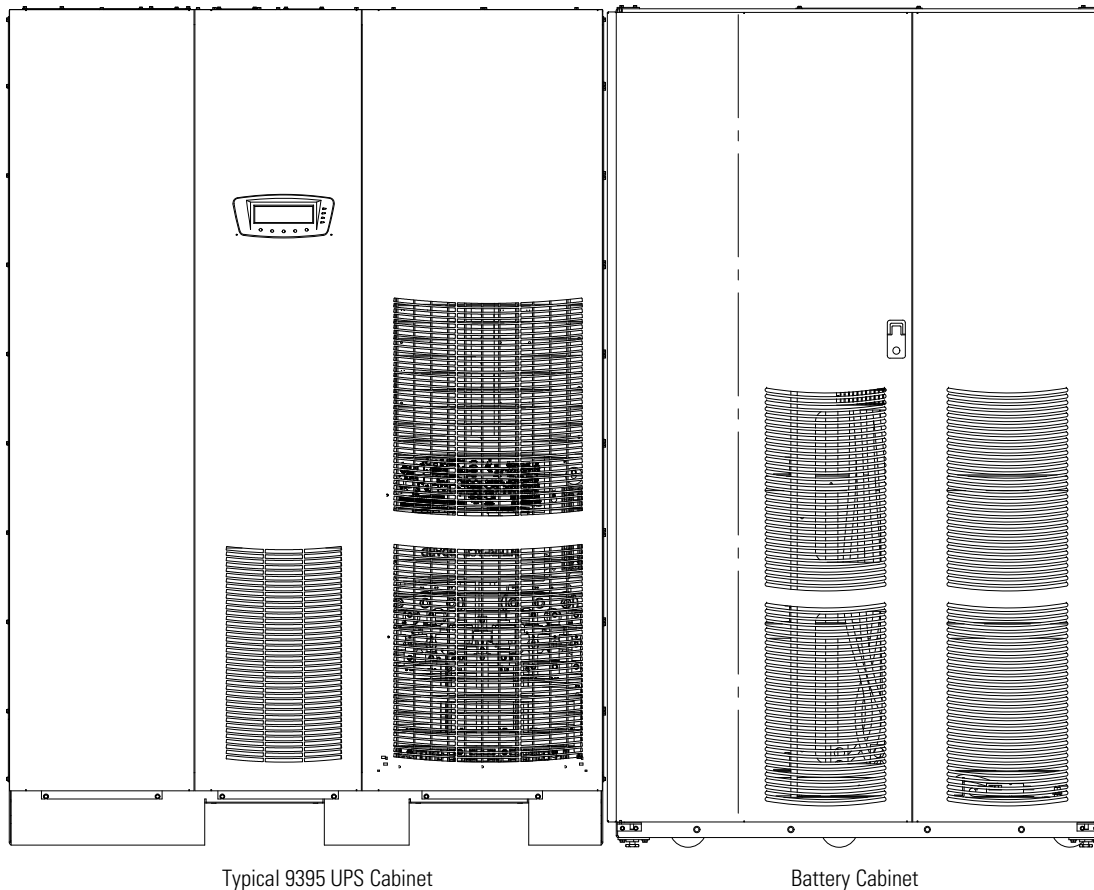
The 1085 and 1085HR battery cabinets CANNOT be intermixed. Serious damage to equipment may result.

---

#### 4.3.1 Mechanical Installation

Use this procedure to install the battery cabinet. The battery cabinet shown in Figure 4-2 is located adjacent to the UPS cabinet, but may be located in a separate location.

There are no battery cabinet-to-UPS mechanical attachment requirements for this type of system. However, individual battery cabinets must be attached and grounded to each other, as described in this section.



**Figure 4-2. UPS with Model 1085 or 1085HR Battery Cabinet**

1. Verify that the UPS is properly installed and secured. Refer to the applicable Power Xpert 9395 UPS Installation and Operation manual listed in paragraph 1.7 for UPS cabinet conduit and terminal specifications and locations.
2. Roll the battery cabinet to the area where the battery cabinet is to be installed.
3. Secure the battery cabinet position by lowering the leveling feet until the cabinet is not resting on the casters and the cabinet is level.




**NOTE** When multiple battery cabinets are ordered for standalone installation, the first battery cabinet is supplied with two cosmetic covers. Additional battery cabinets are supplied without cosmetic covers.

4. Remove the cosmetic cover and hanger brackets from the appropriate side or sides of the battery cabinets, depending on the position of the cabinets. Save covers, screws, and brackets for later use.
5. Roll the next battery cabinet to be joined to an area near the appropriate side of the first battery cabinet.
6. Push the battery cabinet to be joined towards the first battery cabinet until the doors are flush with each other.

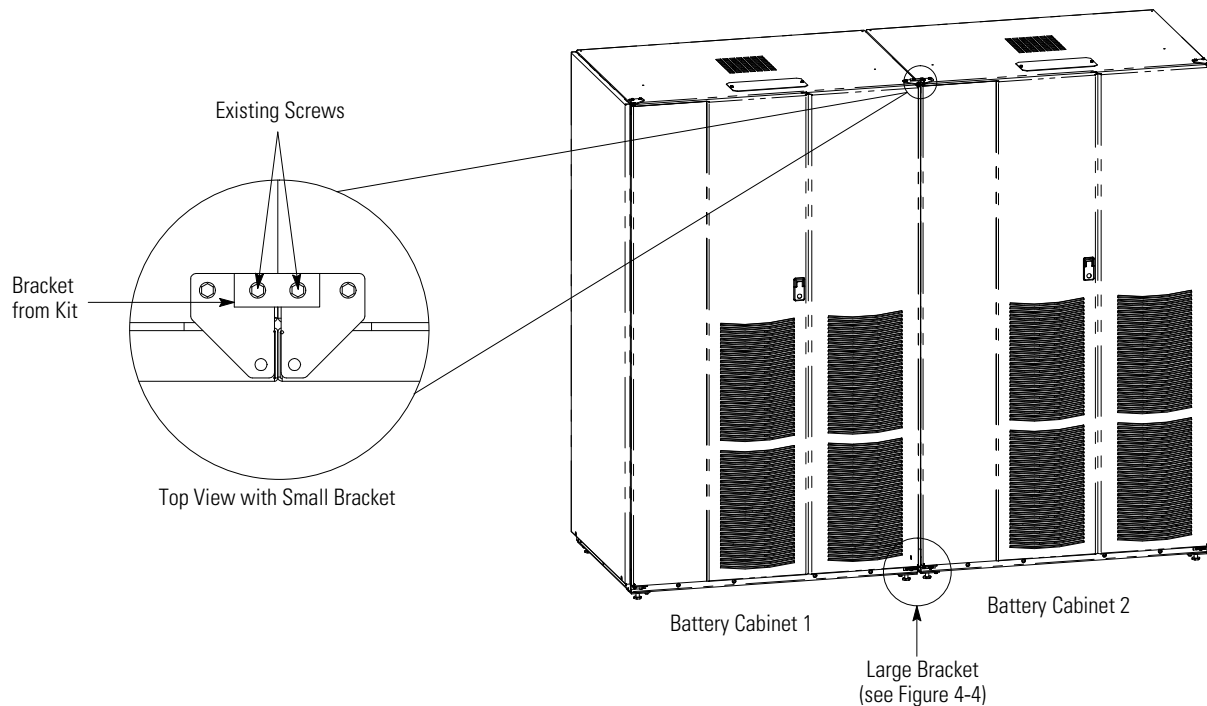
7. Secure the battery cabinet position by lowering the leveling feet until the cabinet is not resting on the casters. Ensure the cabinet is level and matches the height of the first installed battery cabinet.

---

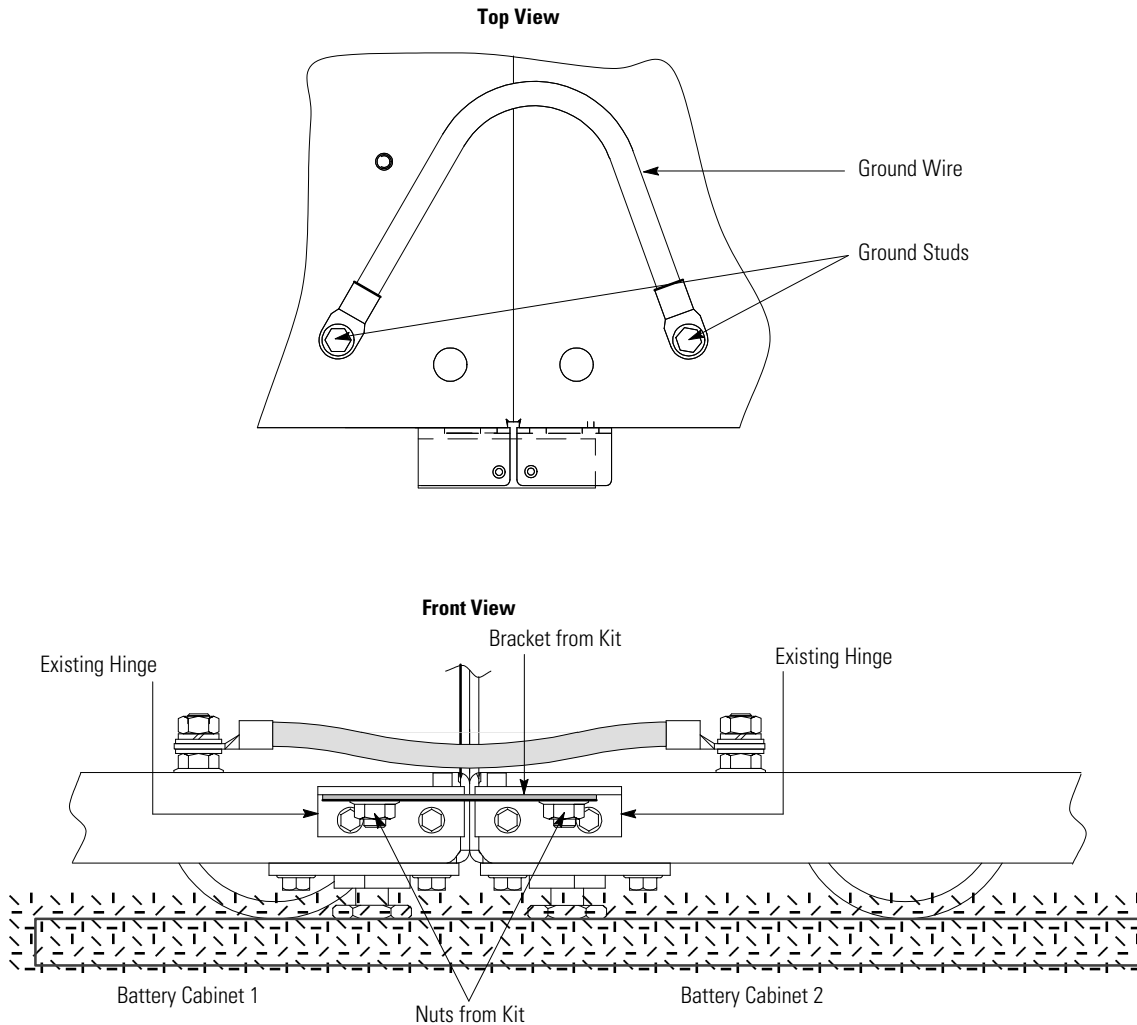
**NOTE**  Two cabinet joining brackets are provided for securing each cabinet at the top and bottom. A flat bracket joins the top of the cabinets and a larger flat bracket joins the cabinets at the bottom. The small flat bracket is attached to the cabinet tops first.

---

8. Remove the left-hand and right-hand screws from the adjacent top door hinges of the battery cabinets.
9. Locate the small flat bracket from the field kit. Align the holes in the small flat bracket over the hinge screw holes. Replace the screws in the hinges, securing the bracket to the cabinets (see Figure 4-5).
10. Locate the large flat bracket from the field kit. Place the bracket over the bolts on the bottom side of the adjacent lower hinges on the battery cabinets (see Figure 4-6).

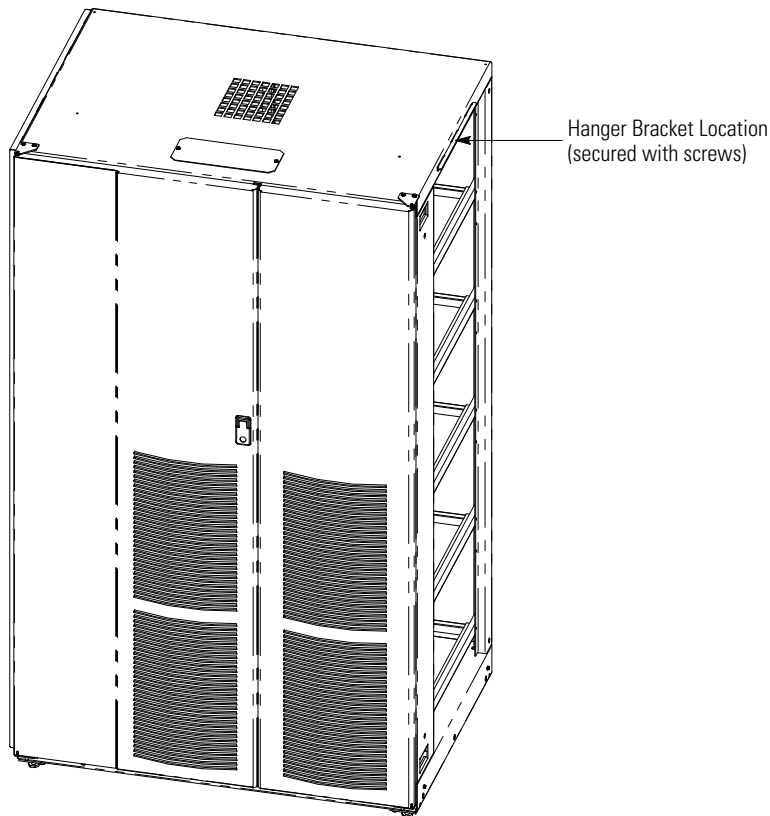


**Figure 4-3. Battery Cabinet to Battery Cabinet Joining Brackets**



**Figure 4-4. Battery Cabinet Bottom Joining Brackets and Ground Wire**

11. Secure the bracket to the hinges with hardware from the field kit.
12. Route the ground wire (from the field kit) from the ground stud in one battery cabinet, under the lower battery tray and through the cabinet-to-cabinet cable access area in the side of the cabinets, and attach to the ground stud in the other battery cabinet (see Figure 4-4). Hardware is provided on each ground stud.
13. If installing additional battery cabinets, repeat Steps 4 through 12 to join each additional battery cabinet; otherwise, proceed to Step 14.
14. If not already installed, mount the hanger brackets to the top appropriate side of the last battery cabinet using M4 screws (see Figure 4-5).
15. If not already installed, hang the side panel on the hanger brackets and align with the front and rear of the battery cabinet.
16. If not already secured, secure the side panel at the bottom using M4 hex-head screws previously removed.
17. Proceed to paragraph 4.3.2.



**Figure 4-5. Battery Cabinet Hanger Bracket Location**

### 4.3.2 External Power Wiring Installation

**NOTE** The battery cabinet is shipped with a debris shield covering the ventilation grill on top of the unit. Do not remove the debris shield until installation is complete. However, remove the shield before using the battery cabinet. Once the debris shield is removed, do not place objects on the ventilation grill.



**NOTE** Remove the battery cabinet top or bottom conduit landing plate to drill or punch conduit holes (see Figure 4-6).

**NOTE** Wiring is installed externally between each battery cabinet and the UPS or battery disconnect using conduit (see Figure 5-1 through Figure 5-4).

**NOTE** All battery cabinets have to be directly connected to the UPS or battery disconnect, not daisy-chained through each cabinet. All power wiring between the UPS and/or battery disconnect is customer supplied.

To install wiring connections:



**LETHAL VOLTAGE** is present when performing the remaining steps in this section and subsequent sections.

---

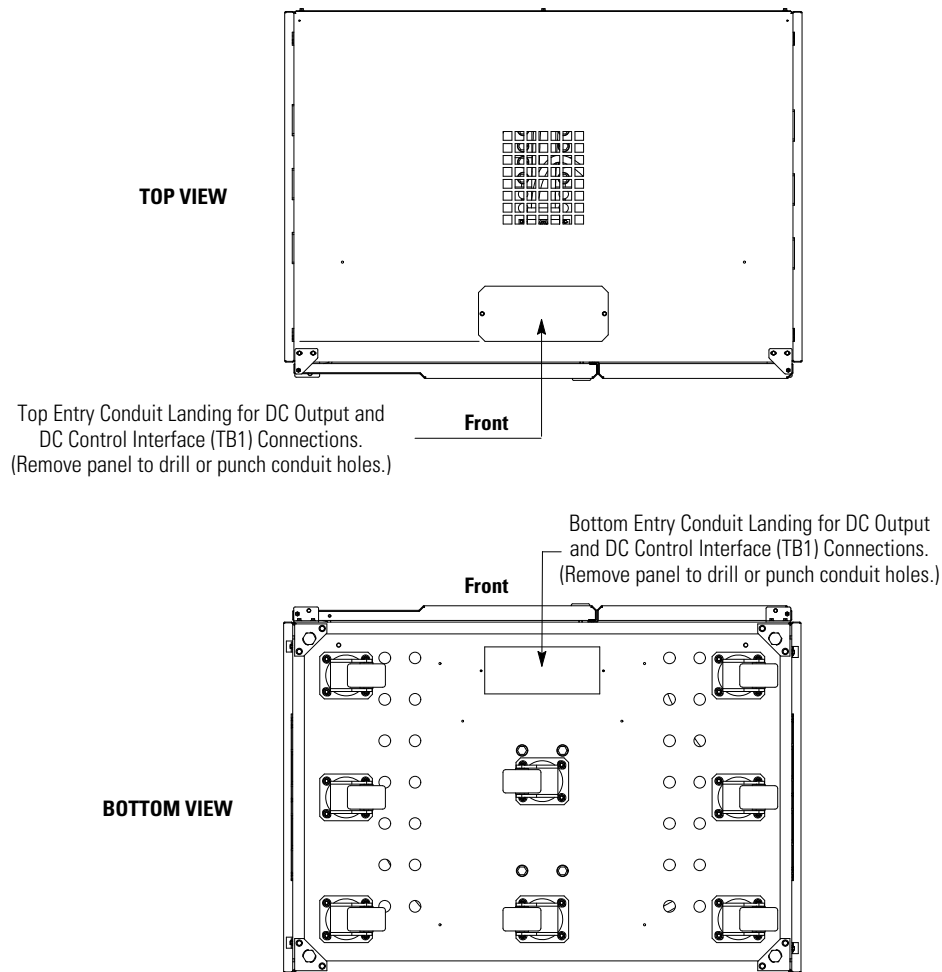
**CAUTION**

---

The 1085 and 1085HR battery cabinets CANNOT be intermixed. Serious damage to equipment may result.

---

1. Route one end of the battery cables through either the top or bottom of the cabinet to the battery terminals. See paragraph 3.2.2 for wiring and termination requirements. See Figure 4-6 and Figure 4-7 for wiring access information and terminal locations.
2. Connect the positive, negative, and ground power wiring to the battery cabinet terminals (see Figure 4-7). Use pressure and bus bar terminations as necessary.

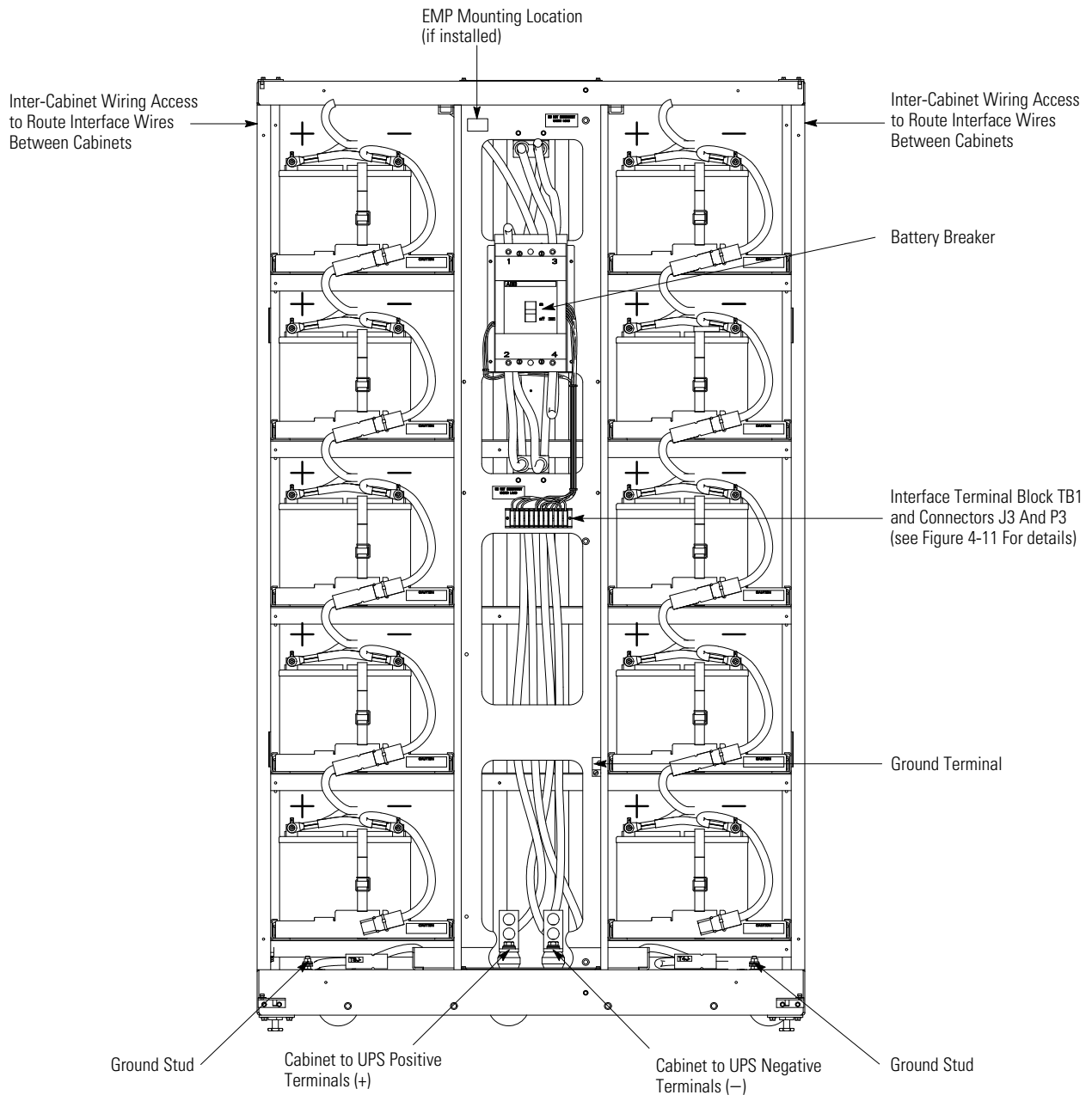


**Figure 4-6. Battery Cabinet Conduit and Wire Entry Locations**

3. If wiring to a battery disconnect, proceed to Step 6; otherwise, proceed to Step 4.
4. Follow the required battery cable routing instructions specified in Section 3.2.2 above. Route and connect the other end of the battery cables to the UPS cabinet battery input terminals E4 and E5 and ground terminals. Refer to the applicable Power Xpert 9395 Installation and Operation manual listed in paragraph 1.7 for UPS cabinet terminal locations and termination requirements.
5. Proceed to Step 8.



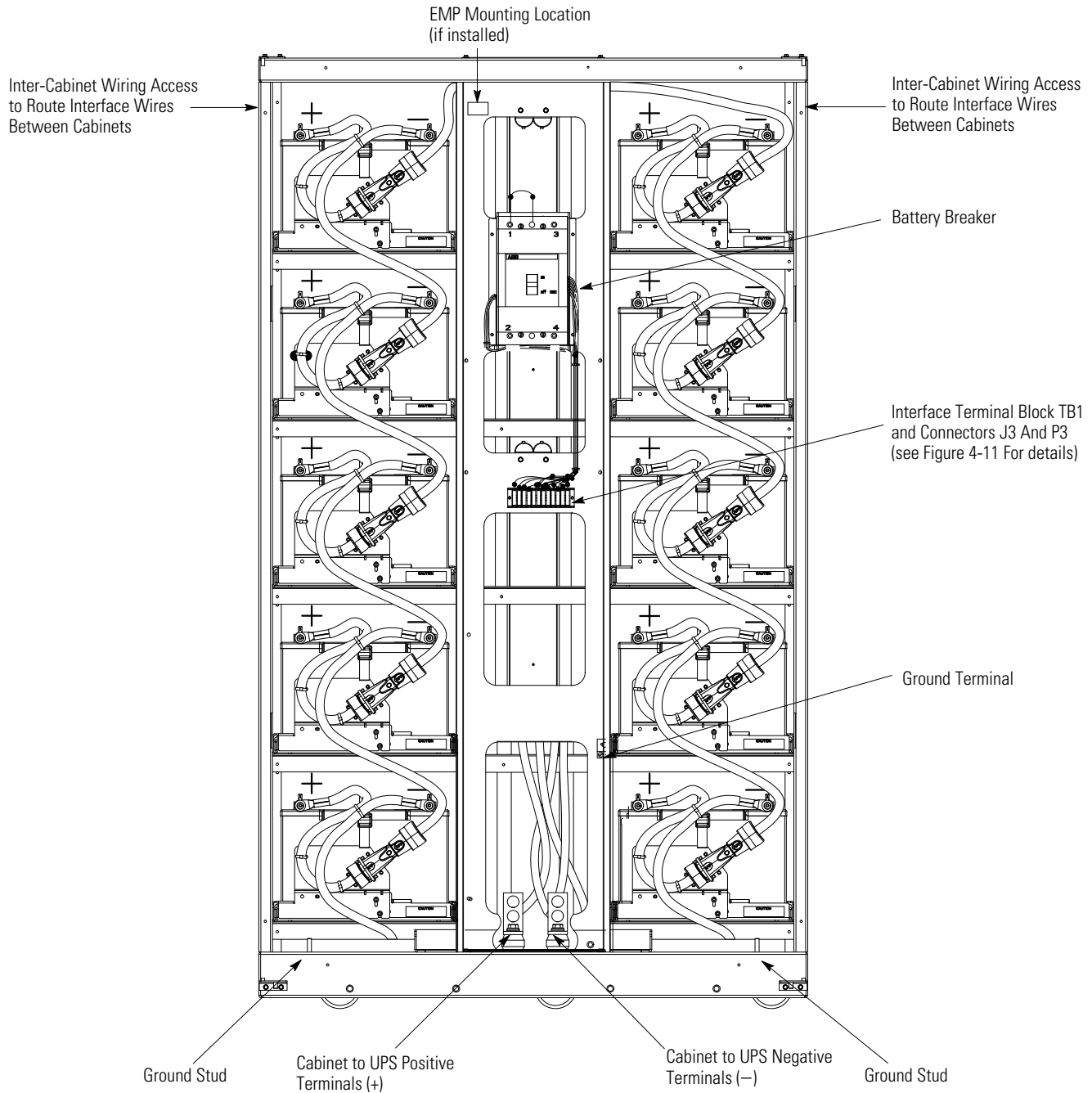
6. Follow the required battery cable routing instructions specified in Section 3.2.2 above. Route and connect the other end of the battery output cables to the battery disconnect input terminals. Refer to the applicable installation instructions for the battery disconnect for terminal locations and termination requirements.
7. Route and connect the battery disconnect output cables to the UPS cabinet battery input terminals E4 and E5 and ground terminals. Refer to the applicable Power Xpert 9395 Installation and Operation manual listed in paragraph 1.7 for UPS cabinet terminal locations and termination requirements.
8. Repeat Steps 1 through 7 for each battery cabinet, and then proceed to paragraph 4.3.3.



**NOTE** Use pressure and bus bar terminations as necessary for connecting cables between the UPS and battery cabinets.

**Figure 4-7. 1085 Battery Power and Interface Terminal Locations**

# Installation



**NOTE** Use pressure and bus bar terminations as necessary for connecting cables between the UPS and battery cabinets.

**Figure 4-8. 1085HR Battery Power and Interface Terminal Locations**

### 4.3.3 External Interface Wiring Installation



**NOTE** Remove the battery cabinet top or bottom conduit landing plate to drill or punch conduit holes (see Figure 4-6).



**DANGER**

**LETHAL VOLTAGE** is present near the user interface terminal area.

To install wiring connections:

1. To locate the appropriate terminations and inter-cabinet wiring access points, see Figure 4-7. To review the interface wiring requirements, see paragraph 3.2.3, the applicable Table 4-1 and Figure 4-9 or Table 4-2 and Figure 4-10.
2. In the first battery cabinet, locate the battery-cabinet-to-battery-cabinet Shunt Trip (or UVR) and Aux battery interface cable with connector P3. Route this connector into the next cabinet and mate with the matching J3 connector in that cabinet (see Figure 4-9 through Figure 4-13, and Figure 5-6 through Figure 5-8).
3. In the middle battery cabinets, locate the battery-cabinet-to-battery-cabinet Shunt Trip (or UVR) and Aux battery interface cable with connector P3. Route this connector into the next cabinet and mate with the matching J3 connector in that cabinet (see Figure 4-9 through Figure 4-13, and Figure 5-6 through Figure 5-8). Continue until all battery cabinets are inter-connected.
4. On the first and middle battery cabinet TB1 terminal boards, disconnect the jumper from terminal 4 and connect to terminal 5. On the last battery cabinet TB1 terminal board, verify the jumper is connected between terminals 4 and 10. See Figure 4-11 through Figure 4-13, and Figure 5-6 through Figure 5-8.
5. If wiring a battery disconnect, proceed to Step 9; otherwise, proceed to Step 6.

**NOTE** The 9395 system can trip a maximum of six battery cabinets total. This applies to both the 1085 standard and High Rate series batteries. If more than six battery cabinets in total are needed in a separate UPM battery configuration, DO NOT hook up the shunt trips. Instead, use external hardware to perform the shunt trip function.



**NOTE** When installing Shunt Trip and Aux battery interface wiring to the UPS interface terminals, conduit must be installed between the UPS and the first battery cabinet.

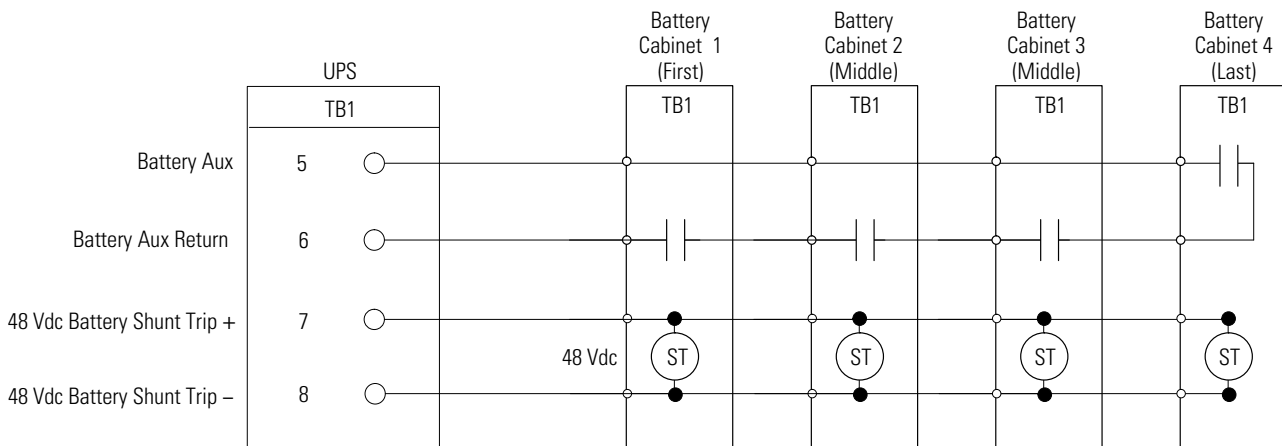
**NOTE** All interface wiring between the UPS and the first battery cabinet is customer supplied.

6. Route the Shunt Trip (or UVR) and Aux battery wiring from the first battery cabinet TB1 terminals (see Figure 4-9 to Figure 4-11, and Figure 5-6) to the UPS interface terminals through conduit. Use top or bottom entry.
7. Connect the wiring to terminal strip TB1 in the battery cabinet (see Figure 4-11). Connect the wiring to terminal strip TB2 in the UPS cabinet. Refer to the applicable Power Xpert 9395 Installation and Operation manual listed in paragraph 1.7 for UPS cabinet terminal locations and assignments, and termination requirements.
8. Proceed to Step 13.
9. Route only the Aux battery wiring from the first battery cabinet TB1 terminals (see Figure 4-9 to Figure 4-11, and Figure 5-6) to the battery disconnect interface terminals through conduit. Use top or bottom entry on the battery cabinet.

10. Connect the Aux battery wiring to terminal strip TB1 in the battery cabinet (see Figure 4-11). Connect the wiring to terminals in the battery disconnect. The battery disconnect Aux battery wiring must be in series with the battery cabinet and the UPS. Refer to the applicable installation instructions for the battery disconnect for terminal locations and assignments, and termination requirements.
11. Route the Shunt Trip (or UVR) and Aux battery wiring from the battery disconnect terminals to the UPS interface terminals through conduit. Use top or bottom entry on the UPS cabinet. Refer to the applicable installation instructions for the battery disconnect for terminal locations and termination requirements.
12. Connect the wiring to the terminals in the battery disconnect. Connect the wiring to terminal strip TB2 in the UPS cabinet. Refer to the applicable Power Xpert 9395 Installation and Operation manual listed in paragraph 1.7 for UPS cabinet terminal locations and assignments, and termination requirements.
13. Proceed to paragraph 4.3.4.

**Table 4-1. TB1 Interface Connections**

Terminal TB1	Name	Description
1	CB1 Aux 1 Switch NC	
2	CB1 Aux 1 Switch Com	Auxiliary battery breaker dry contacts. Not used.
3	CB1 Aux 1 Switch NO	
4	Jumper Tie Points	Multi-cabinet selection.
5	48 Vdc Battery Shunt Trip +	
6	48 Vdc Battery Shunt Trip –	Internal connection to Shunt Trip coil.
8	CB1 Aux 2 Switch NC	Auxiliary battery breaker dry contact. Not used.
9	CB1 Aux 2 Switch Com (Battery Aux Return)	
10	CB1 Aux 2 Switch NO (Battery Aux)	Contacts used to indicate whether UPS battery breaker or disconnect is open or closed.
11	48 Vdc Battery Shunt Trip +	
12	48 Vdc Battery Shunt Trip –	Contacts used to open battery breaker or disconnect.



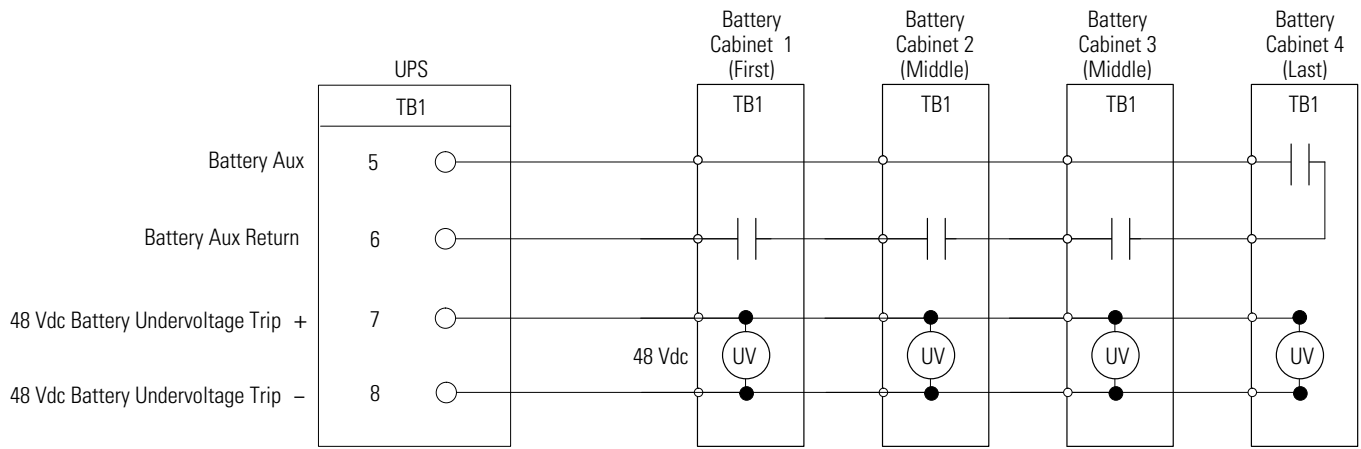
**NOTE** Battery Aux and DC Shunt Trip wiring should be a minimum of 18 AWG.

**Multiple Battery Cabinets**

**Figure 4-9. Battery Breaker Interface Wiring**

**Table 4-2. 9395C TB1 Interface Connections**

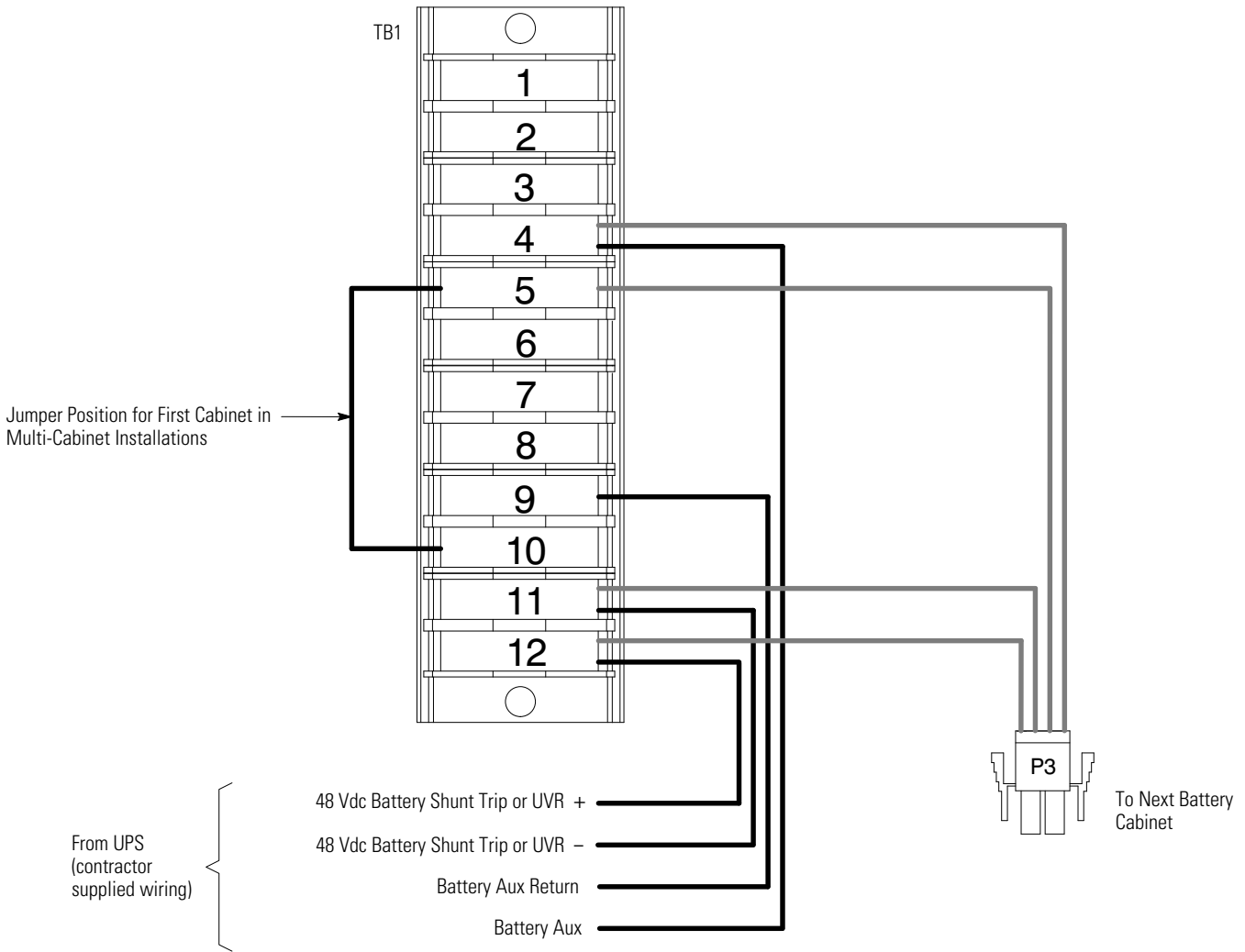
Terminal TB1	Name	Description
1	CB1 Aux 1 Switch NC	
2	CB1 Aux 1 Switch Com	Auxiliary battery breaker dry contacts. Not used.
3	CB1 Aux 1 Switch NO	
4	Jumper Tie Points	Multi-cabinet selection.
5		
6	48 Vdc Battery Undervoltage Trip +	Internal connection to Shunt Trip coil.
7	48 Vdc Battery Undervoltage Trip -	
8	CB1 Aux 2 Switch NC	Auxiliary battery breaker dry contact. Not used.
9	CB1 Aux 2 Switch Com (Battery Aux Return)	Contacts used to indicate whether UPS battery breaker or disconnect is open or closed.
10	CB1 Aux 2 Switch NO (Battery Aux)	
11	48 Vdc Battery Undervoltage Trip +	Contacts used to open battery breaker or disconnect.
12	48 Vdc Battery Undervoltage Trip -	



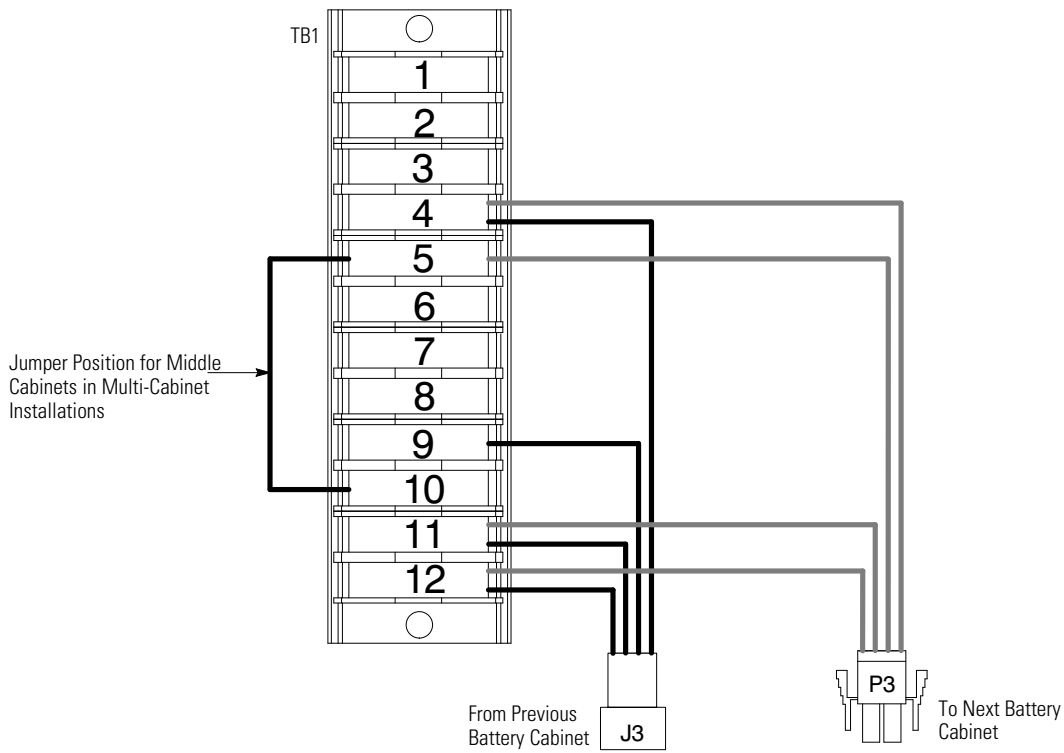
**NOTE** Battery Aux and DC Undervoltage Trip wiring should be a minimum of 18 AWG.

**Multiple Battery Cabinets**

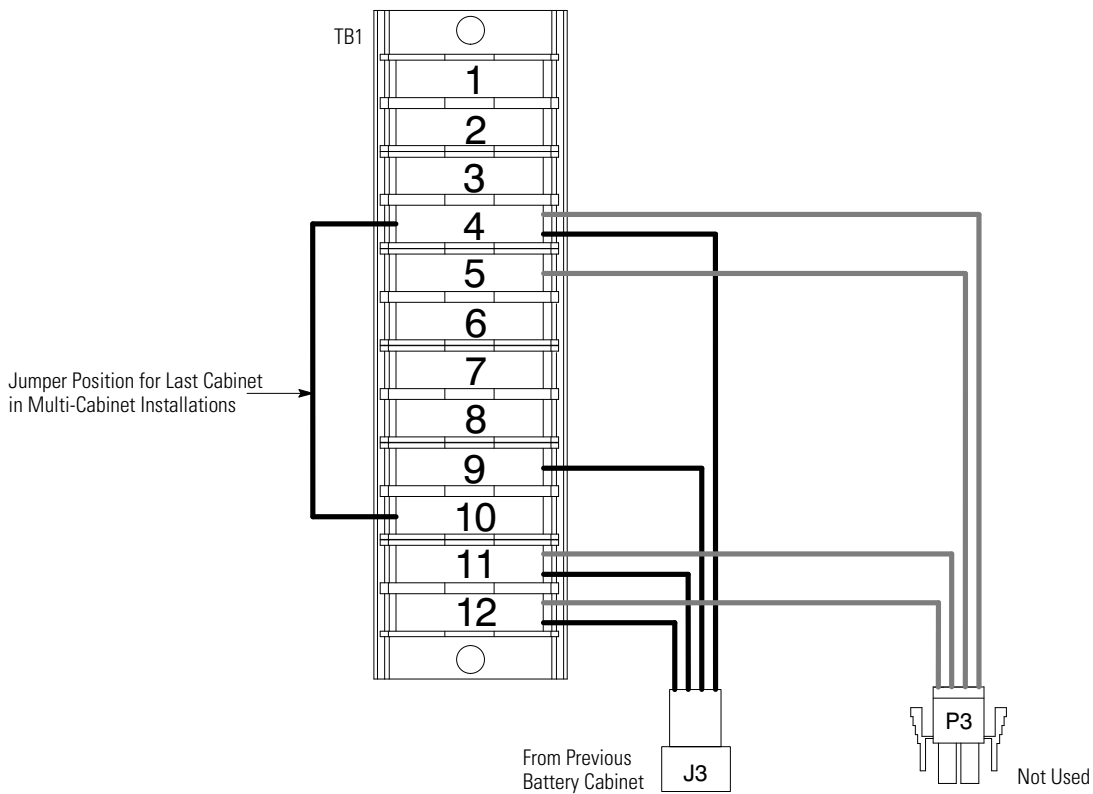
**Figure 4-10. 9395C Battery Breaker Interface Wiring**



**Figure 4-11. Terminal Block TB1 Connector Assignments – First Cabinet**



**Figure 4-12. Terminal Block TB1 Connector Assignments – Middle Cabinets**

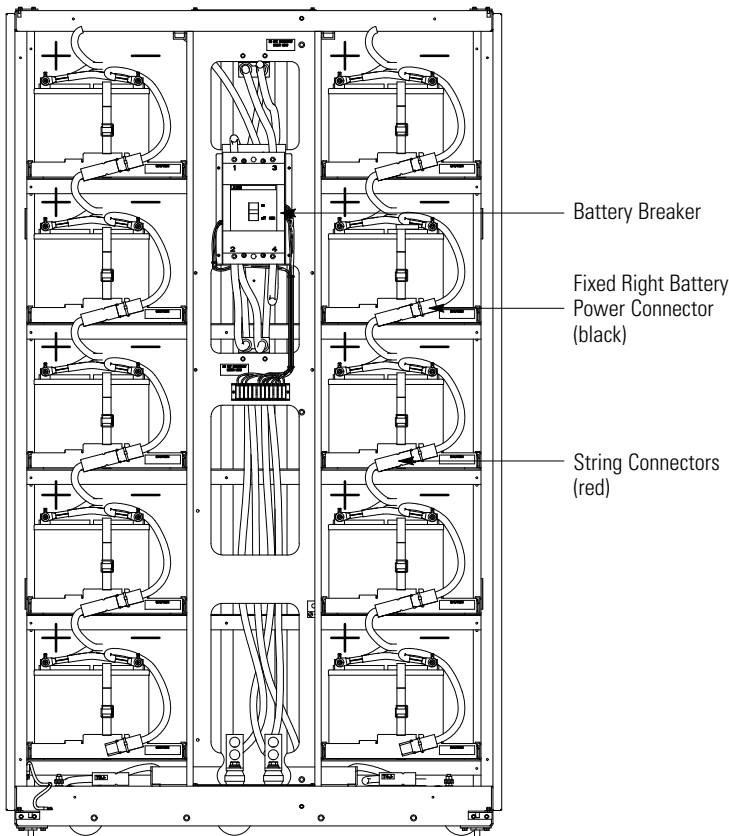


**Figure 4-13. Terminal Block TB1 Connector Assignments – Last Cabinet**

#### 4.3.4 Internal Battery String Connection

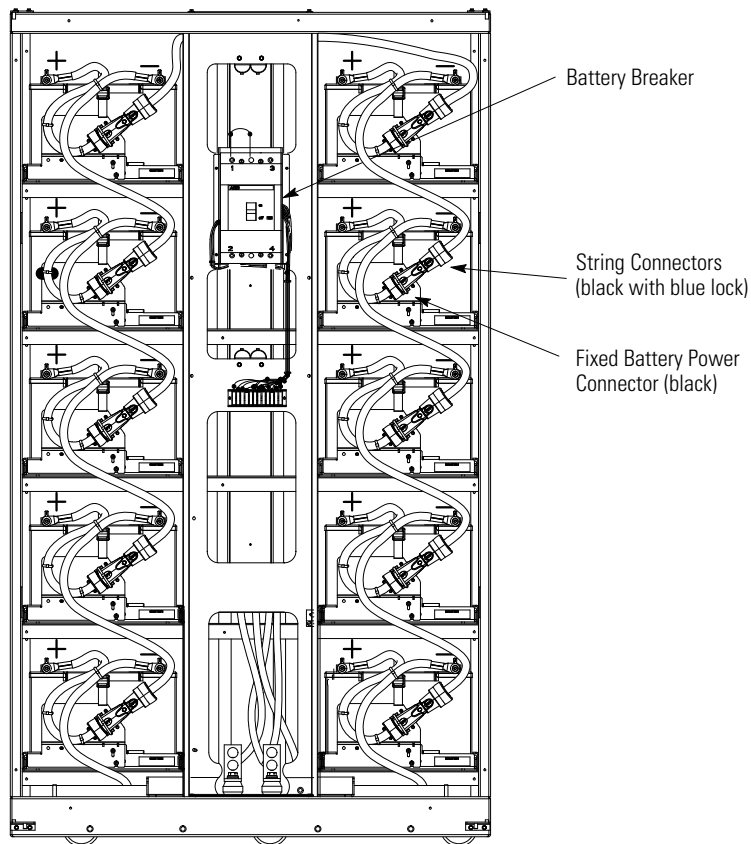
All battery cabinets arrive at the site with each battery connection string electrically disconnected. To interconnect the battery tray strings:

1. Verify that all battery breakers are in the OFF position.
2. **FOR 1085 ONLY:** Connect the string of battery trays by mating the loose red connector from each tray to the fixed black connector mounted on the front edge of the tray above. Connect the top and bottom tray connectors to the mating cabinet connectors to complete the battery string connections (see Figure 4-14).
3. **FOR 1085HR ONLY:** Connect the string of battery trays by mating the loose black connector with the blue locking mechanism from each tray to the fixed black connector mounted on the front edge of the tray below. Connect the top and bottom tray connectors to the mating cabinet connectors to complete the battery string connections (see Figure 4-15).
4. Repeat Step 2 or Step 3 for each battery cabinet, and then proceed to Step 5.
5. Replace the doors that were removed in paragraph 4.2.
6. Secure all battery cabinets by closing and latching the doors.
7. Return to the appropriate Power Xpert 9395 UPS Installation and Operation manual, as referenced in paragraph 1.7 to complete the UPS wiring.



**Figure 4-14. 1085 Battery String Connection**





**Figure 4-15. 1085HR Battery String Connection**

#### 4.4 Initial Startup

Startup and operational checks must be performed by an authorized Eaton Customer Service Engineer, or the warranty terms specified on page W-1 become void. This service is offered as part of the sales contract for the UPS. Contact service in advance (usually a two-week notice is required) to reserve a preferred startup date.

#### 4.5 Completing the Installation Checklist

The final step in installing the battery cabinet is to complete the Installation Checklist. This checklist ensures all hardware, cables, and other equipment have been installed. Completing all items on the checklist will ensure a smooth installation. Make a copy of the Installation Checklist before filling it out, and retain the original.

After completing your installation, a service representative will be able to verify the operation of the battery cabinet and commission it to support the critical load. The service representative cannot perform any installation tasks other than verifying that the battery cabinet has been correctly installed. Service personnel may request a copy of the completed Installation Checklist to be sure all applicable equipment installation requirements have been completed.

---

The Installation Checklist **MUST** be completed prior to starting the battery system for the first time.

---



### Installation Checklist

- All packing materials and restraints have been removed from each cabinet.
- Each cabinet in the UPS system is placed in its installed location.
- A cabinet grounding/mounting kit is installed between the ISBM and UPM sections.
- All conduits and cables are properly routed to the UPS and any ancillary cabinets.
- All power cables are properly sized and terminated.
- Battery cables are terminated on E4 (+) and E5 (.).
- Battery aux contact signal wiring is connected from the UPS to the battery disconnect.
- Battery shunt trip signal wiring is connected from the UPS to the battery disconnect. (OPTIONAL)
- LAN drops are installed.
- All LAN connections have been completed.
- A ground conductor is properly installed.
- Air conditioning equipment is installed and operating correctly.
- The area around the installed UPS system is clean and dust-free. (It is recommended that the UPS be installed on a level floor suitable for computer or electronic equipment.)
- Adequate workspace exists around the UPS and other cabinets.
- Adequate lighting is provided around all UPS equipment.
- A 120 Vac service outlet is located within 7.5 meters (25 feet) of the UPS equipment.
- The REPO device is mounted in its installed location and its wiring is terminated inside the UPS cabinet.
- The normally-closed (NC) Emergency Power-off contact (pins 1 and 2 on TB1) is jumpered if not used.
- Alarm relays and building alarms are wired appropriately. (OPTIONAL)
- A remote battery disconnect is mounted in its installed location and its wiring is terminated inside the UPS. (OPTIONAL)
- Accessories are mounted in installed locations and wiring is terminated inside the UPS cabinet. (OPTIONAL)
- The debris shields covering the UPS cabinet ventilation grills are removed.
- Startup and operational checks are performed by an authorized Eaton Customer Service Engineer.

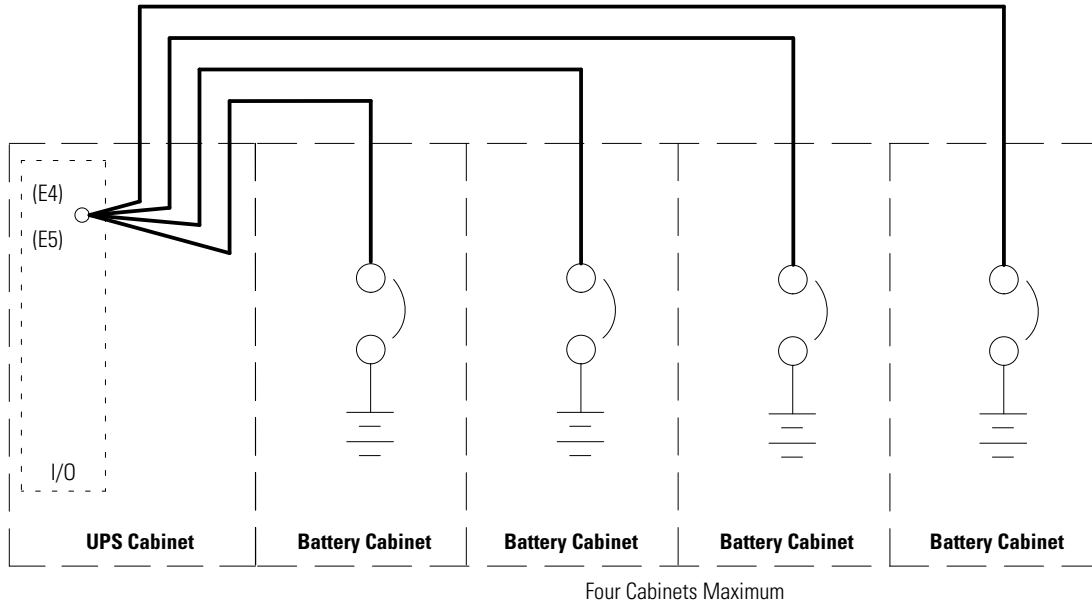


This page intentionally left blank.

## Chapter 5 Oonline Drawings and Schematics

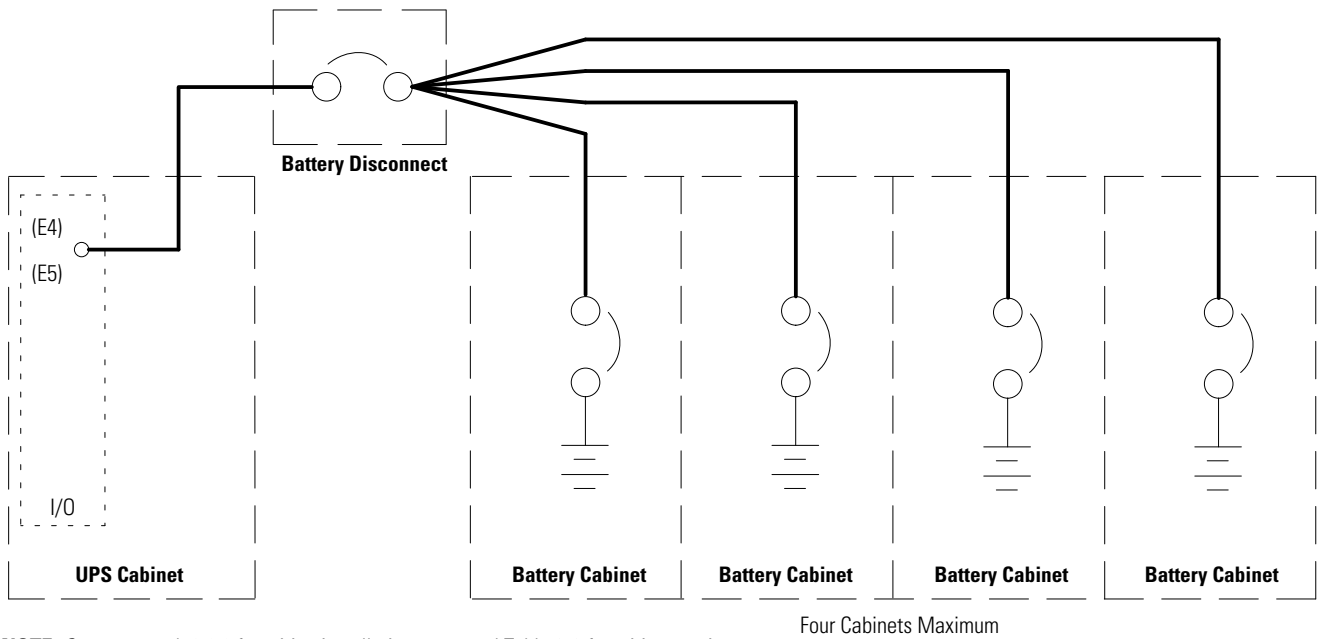
### 5.1 Oonline Drawings

Figure 5-1 through Figure 5-4 show the battery cabinet oonline drawings.



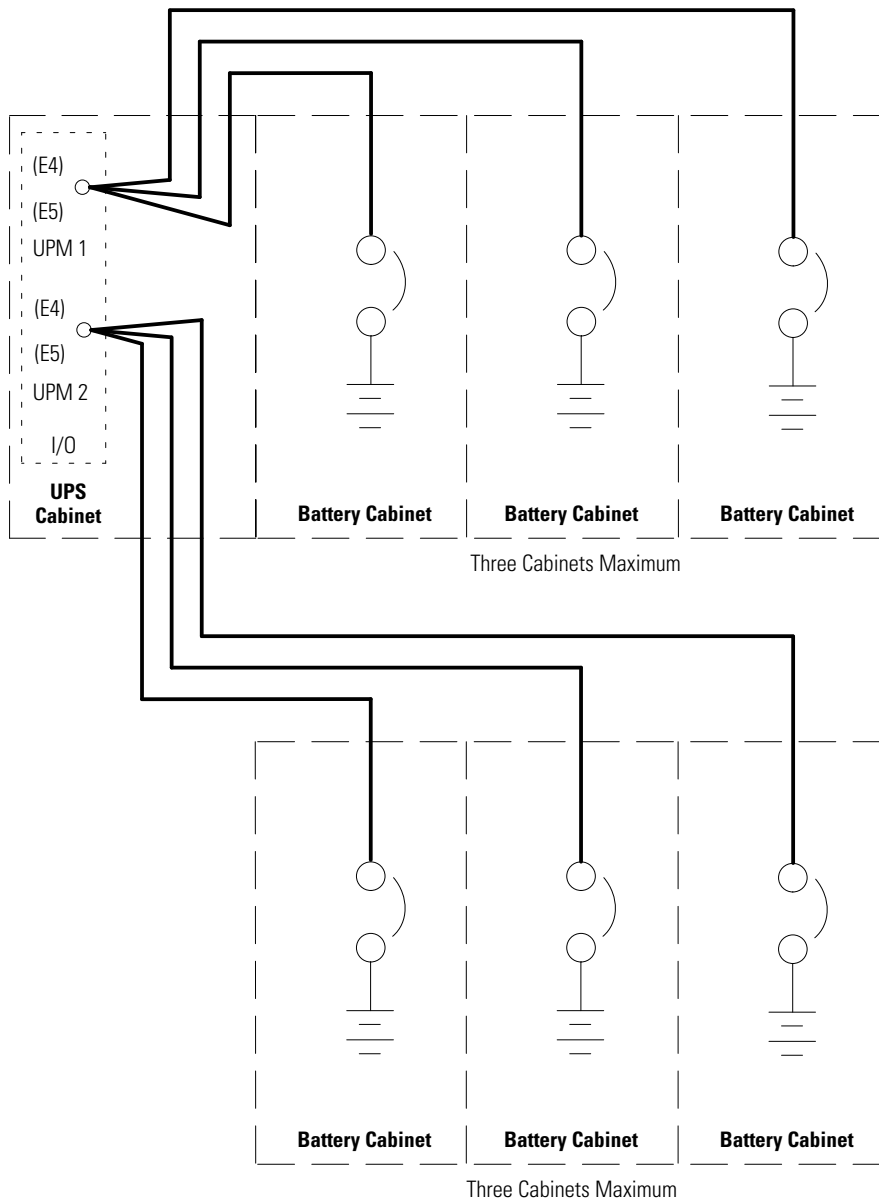
**NOTE** See paragraph 3.2.2 for wiring installation notes and Table 3-3 for wiring requirements.

**Figure 5-1. Battery Cabinet Oonline – Common Battery (275 and 500 kVA RT and 275 kVA Plus 1 UPS)**



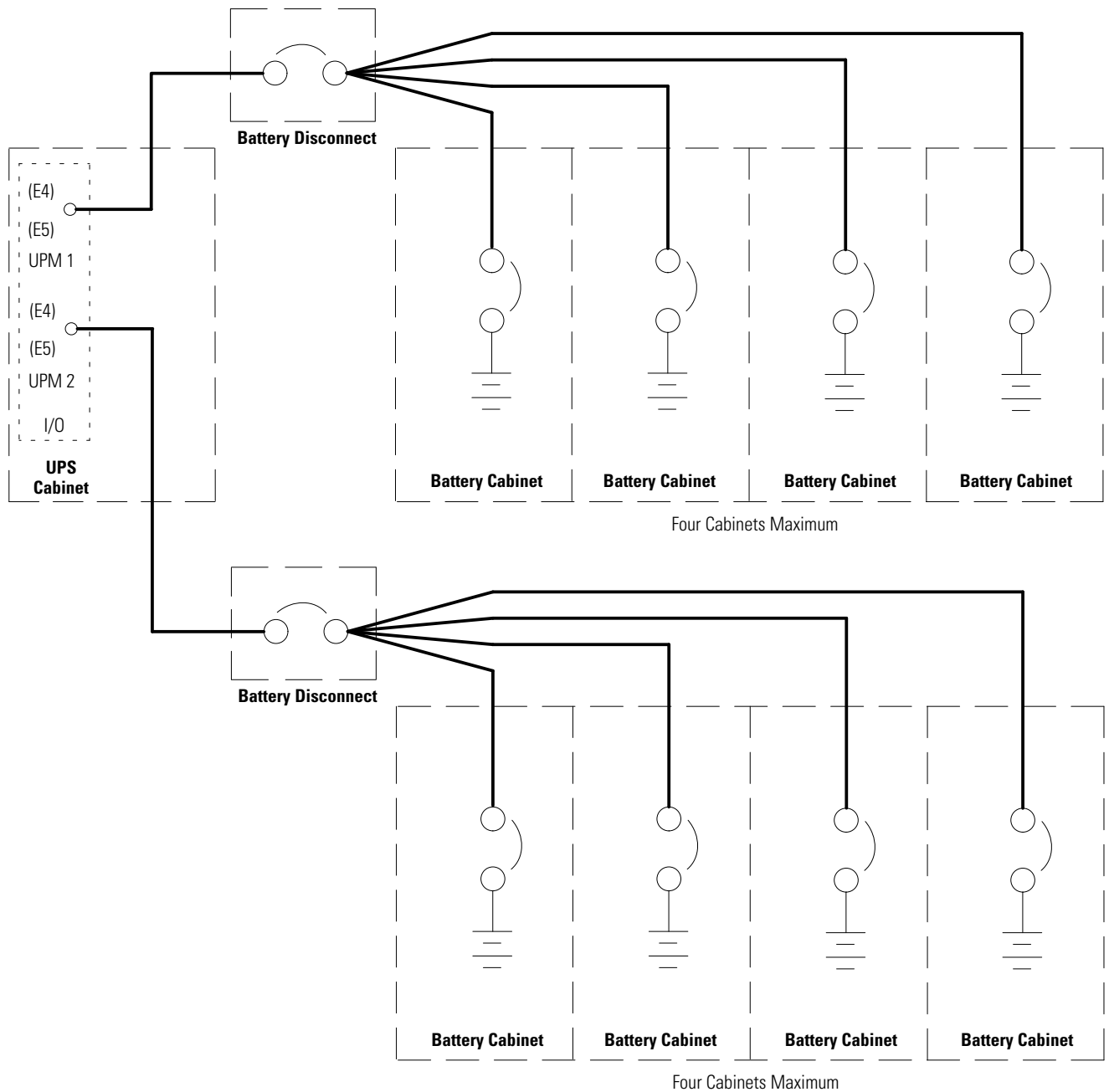
**NOTE** See paragraph 3.2.2 for wiring installation notes and Table 3-3 for wiring requirements.

**Figure 5-2. Battery Cabinet Oonline with Disconnect – Common Battery (275 and 500 kVA RT and 275 kVA Plus 1 UPS)**



**NOTE** See paragraph 3.2.2 for wiring installation notes and Table 3-3 for wiring requirements.

**Figure 5-3. Battery Cabinet Online – Separate Battery (275 kVA Plus 1 and 500 kVA RT UPS)**

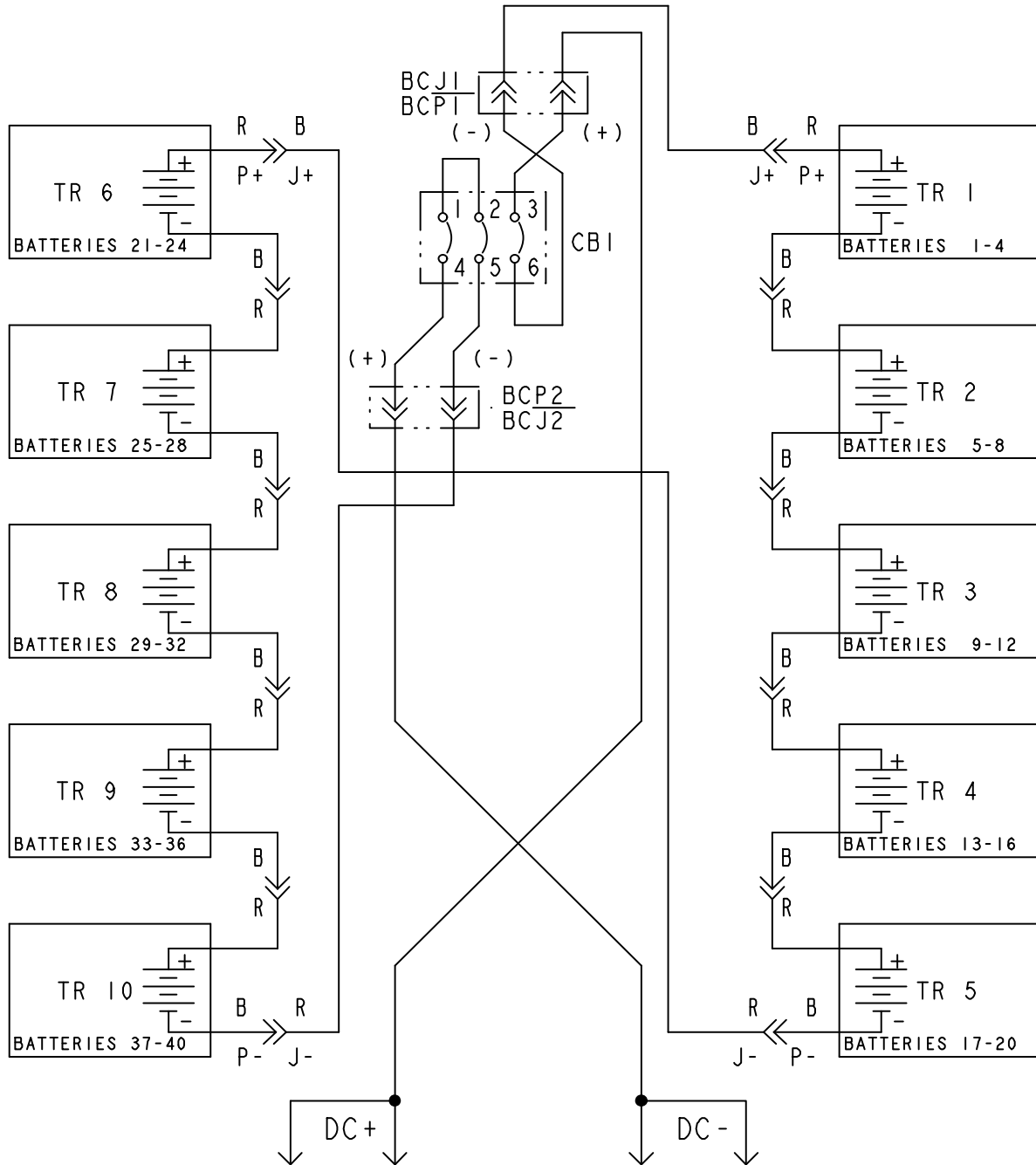


**NOTE** See paragraph 3.2.2 for wiring installation notes and Table 3-3 for wiring requirements.

**Figure 5-4. Battery Cabinet Oneline with Disconnect – Separate Battery (275 kVA Plus 1 and 500 kVA RT UPS)**

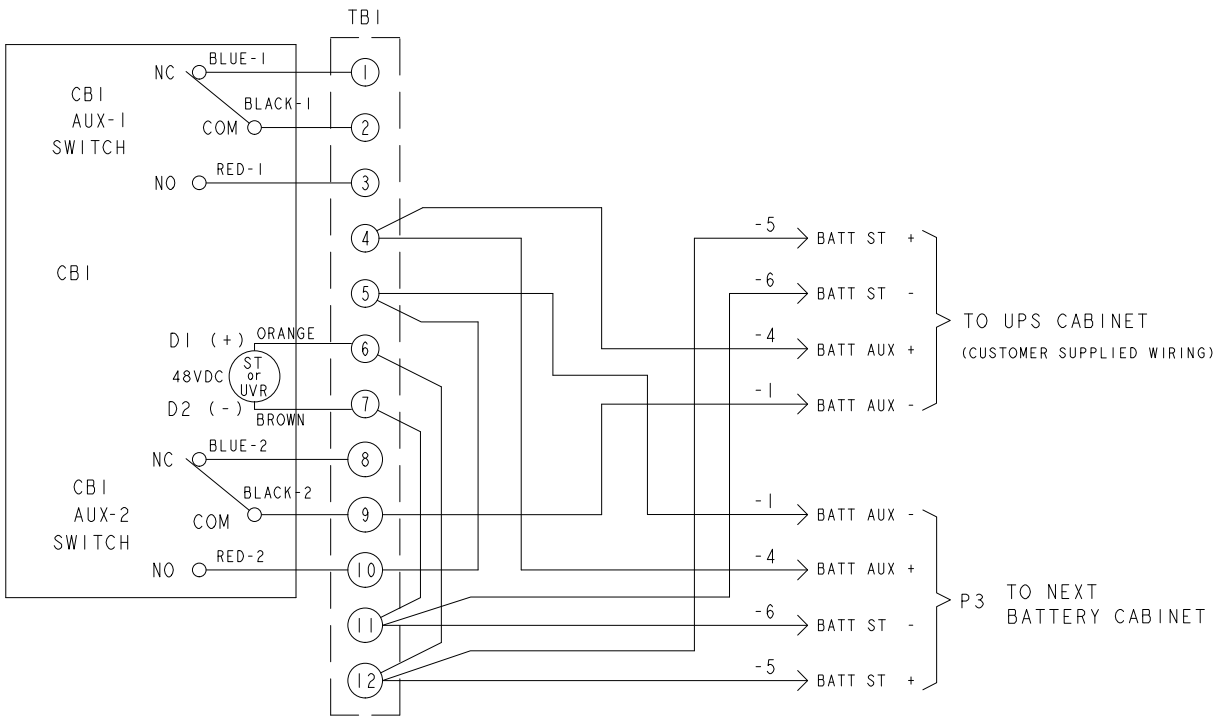
## 5.2 Schematics

Figure 5-5 show the battery cabinet three-pole internal power wiring. Figure 5-6 through Figure 5-8 show the battery cabinet breaker CB1 control wiring.



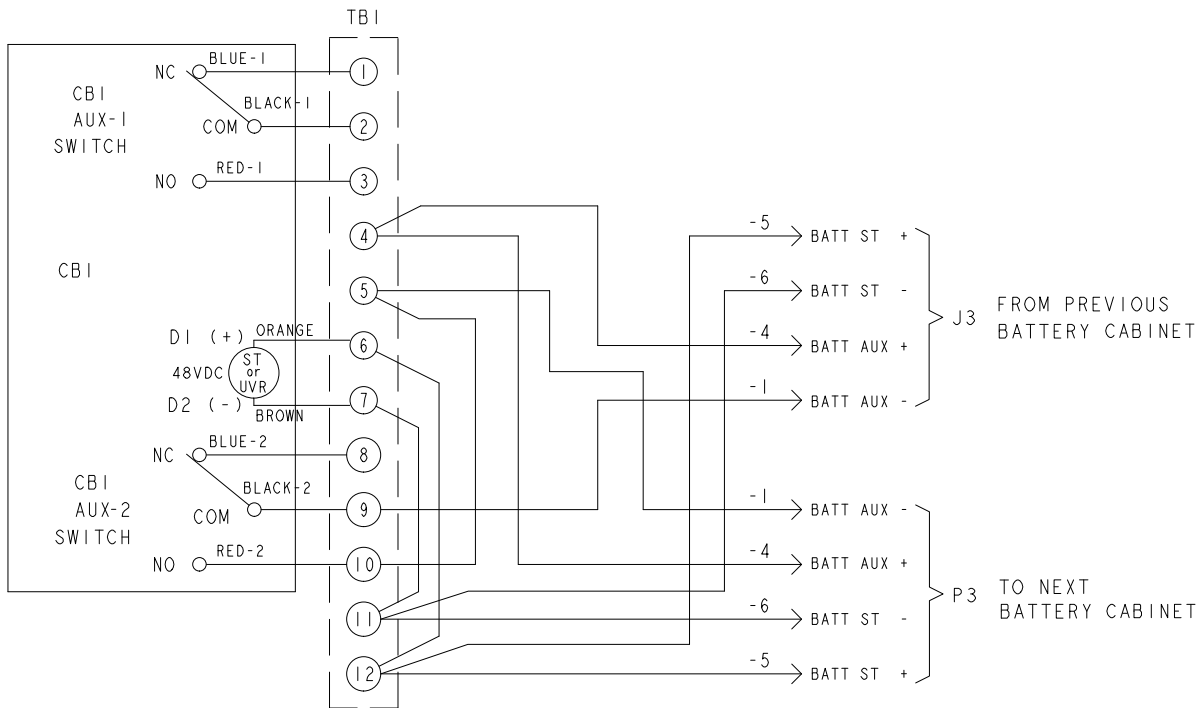
**Figure 5-5. 1085 or 1085HR Battery Cabinet with Three-Pole Breaker Power Wiring Schematic**





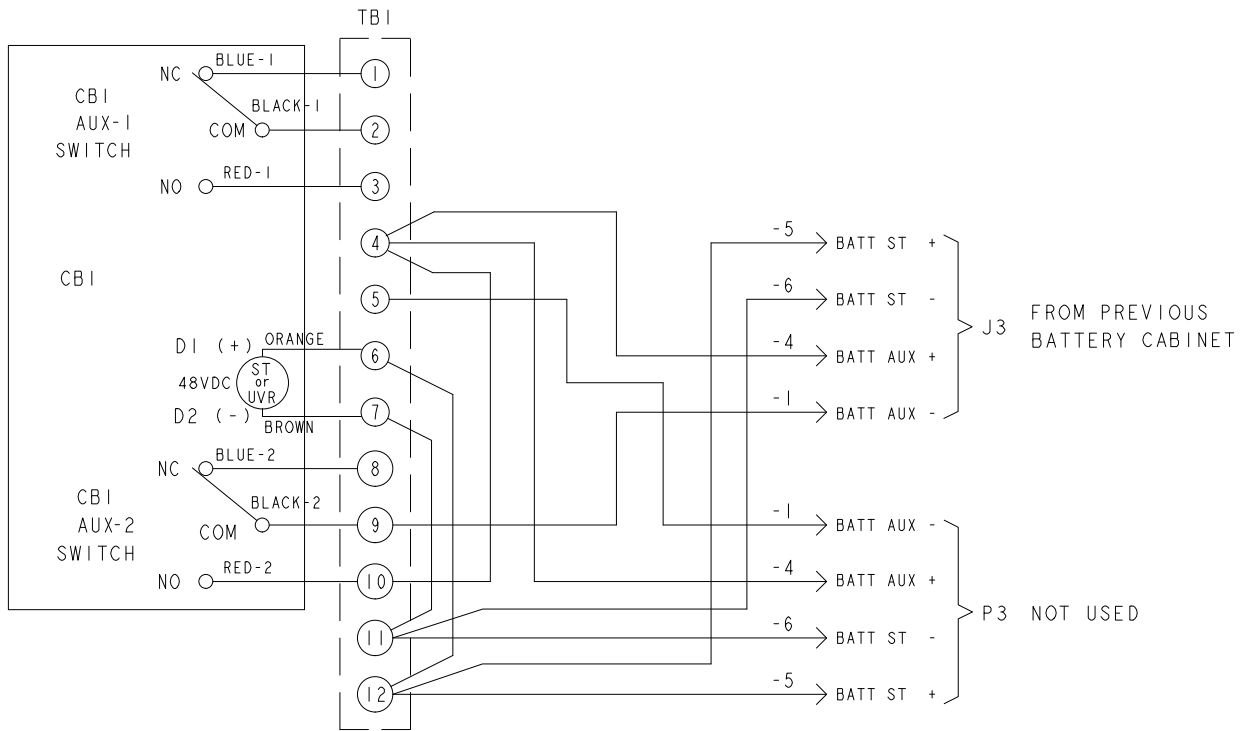
First Cabinet in Multi-Cabinet Installations

**Figure 5-6. Battery Cabinet Breaker CB1 Control Wiring Schematic – First Cabinet**



Middle Cabinets in Multi-Cabinet Installations

**Figure 5-7. Battery Cabinet Breaker CB1 Control Wiring Schematic – Middle Cabinets**



Last Cabinet in Multi-Cabinet Installations

**Figure 5-8. Battery Cabinet Breaker CB1 Control Wiring Schematic – Last Cabinet**

## Chapter 6 Maintenance

The components inside the battery cabinet are secured to a sturdy metal frame. All repairable parts and assemblies are located for easy removal, with very little disassembly. This design allows authorized service personnel to perform routine maintenance and servicing quickly.

You must schedule periodic performance checks of your battery system to keep it running properly. Regular routine checks of operation and system parameters enable your system to function efficiently for many trouble-free years.

### 6.1 Important Safety Instructions

---

 **WARNING**

---

- Servicing and maintenance should be performed by qualified service personnel only.
- **LETHAL VOLTAGE PRESENT.** This unit should not be operated with the cabinet doors open or protective panels removed. Do not make any assumptions about the electrical state of any in the UPS system.

Because each battery string is an energy source in itself, opening the battery circuit breaker does not de-energize the voltage within the battery string. **DO NOT ATTEMPT TO ACCESS ANY INTERNAL AREA OF THE BATTERY STRING YOURSELF. VOLTAGES ARE ALWAYS PRESENT IN THE BATTERY STRING.** If you suspect that a battery string needs service, contact an Eaton service representative.

If the string requires service, refer to the battery manufacturer's operating manual for instructions on battery maintenance or contact an Eaton service representative.

Observe these precautions when working on or around batteries:

- Remove watches, rings, or other metal objects.
- Use tools with insulated handles.
- Wear rubber gloves and boots.
- Do not lay tools or metal parts on top of batteries.
- Disconnect the charging source prior to connecting or disconnecting terminals.
- Determine if the battery is inadvertently grounded. If it is, remove the source of the ground. Contact with any part of a grounded battery can result in electrical shock. The likelihood of such shock is reduced if such grounds are removed during installation and maintenance.
- When replacing batteries, use the same number of sealed, lead-acid batteries.
- Proper disposal of batteries is required. Refer to your local codes for disposal requirements.
- Do not dispose of batteries in a fire. Batteries may explode when exposed to flame.
- Do not open or mutilate batteries. Released electrolyte is harmful to the skin and eyes. It may be toxic

### 6.2 Performing Preventive Maintenance

The battery cabinet requires very little preventive maintenance. However, the system should be inspected periodically to verify that the units are operating normally and that the batteries are in good condition.

#### 6.2.1 DAILY Maintenance

Perform the following steps daily:

1. Check the area surrounding the battery cabinet. Ensure the area is not cluttered, allowing free access to the unit.

2. Ensure the air intakes (vents on the front door or panels) and the exhaust openings (on top of the battery cabinet) are not blocked.
3. Ensure the operating environment is within the parameters specified in paragraph 3.2.1.

### 6.2.2 BATTERY Maintenance

Contact your service representative for battery maintenance. Battery replacement and maintenance should be performed only by authorized service personnel.


## 6.3 Installing Batteries

---

 **CAUTION**

The 1085 and 1085HR batteries CANNOT be intermixed. Serious damage to equipment may result.

---

 **NOTE** There is no manual DC disconnect device within the UPS.

---

Contact your service representative for battery maintenance. Battery replacement and maintenance should be performed only by authorized service personnel. Install batteries in accordance with the battery and battery cabinet or battery rack manufacturer's instructions.

## 6.4 Recycling the Used Battery or UPS

Contact your local recycling or hazardous waste center for information on proper disposal of the used battery or UPS

---

 **WARNING**

- Do not dispose of the battery or batteries in a fire. Batteries may explode. Proper disposal of batteries is required. Refer to your local codes for disposal requirements.
- Do not open or mutilate the battery or batteries. Released electrolyte is harmful to the skin and eyes. It may be toxic.
- A battery can cause electrical shock, burn from high short-circuit current, or fire. Observe proper precautions.

---

 **AVERTISSEMENT!**

- Une batterie peut présenter un risque de choc électrique, de brûlure, ou d'incendie. Suivre les précautions qui s'imposent.
- Pour le remplacement, utiliser le même nombre et modèle des batteries.
- L'élimination des batteries est réglementée. Consulter les codes locaux à cet effet.

---

 **CAUTION**

Do not discard the batteries in the trash. This product contains sealed, lead-acid batteries and must be disposed of properly. For more information, contact your local recycling/reuse or hazardous waste center.

---

---

 **ATTENTION!**

---

Ne pas jeter les batteries aux ordures. Ce produit contient des batteries au plomb scellées, il est important de l'éliminer convenablement. Pour plus de renseignements, communiquer avec le centre régional de récupération/réutilisation ou d'élimination des déchets dangereux.

---

---

 **CAUTION**

---

Do not discard waste electrical or electronic equipment (WEEE) in the trash. For proper disposal, contact your local recycling/reuse or hazardous waste center.

---

---

 **ATTENTION!**

---

Ne pas éliminer les déchets d'équipements électriques et électroniques (DEEE) aux ordures. Pour connaître la méthode d'élimination appropriée, communiquer avec le centre régional de récupération/réutilisation ou d'élimination des déchets dangereux.

---

This page intentionally left blank.





P-164201687 6